

XP13 (HFC-410A) SERIES UNITS



TABLE OF CONTENTS

Model Number Identification	2
Typical Serial Number Identification	2
Specifications	2
Electrical Data	4
Unit Dimensions	6
Unit Parts Arrangement	7
Operating Gauge Set and Service Valves	8
Recovering Refrigerant from System	10
Unit Placement	11
Removing and Installing Panels	13
New or Replacement Line Set	15
Brazing Connections	17
Flushing Line Set and Indoor Coil	20
Installing Indoor Metering Device	21
Leak Test Line Set and Indoor Coil	22
Evacuating Line Set and Indoor Coil	23
Electrical	24
Servicing Units Void of Charge	25
Unit Start-Up	25
System Refrigerant	25
System Operation	32
Defrost System	32
Maintenance	34
Start-up and Performance Checklist	35
Unit Wiring Diagram and Sequence of Operations	36

The XP13 is a high efficiency residential split-system heat pump unit, which features a scroll compressor and HFC-410A refrigerant. XP13 units are available in sizes ranging from 1 1/2 through 5 tons. The series is designed for use with an indoor unit with an check expansion valve approved for HFC-410A.

⚠ WARNING

Improper installation, adjustment, alteration, service or maintenance can cause personal injury, loss of life, or damage to property.

Installation and service must be performed by a licensed professional installer (or equivalent) or a service agency.

⚠ CAUTION

Physical contact with metal edges and corners while applying excessive force or rapid motion can result in personal injury. Be aware of, and use caution when working near these areas during installation or while servicing this equipment.

⚠ IMPORTANT

The Clean Air Act of 1990 bans the intentional venting of refrigerant (CFCs, HCFCs and HFCs) as of July 1, 1992. Approved methods of recovery, recycling or reclaiming must be followed. Fines and/or incarceration may be levied for noncompliance.

⚠ IMPORTANT

This unit must be matched with an indoor coil as specified in *Lennox XP13 Engineering Handbook*. Coils previously charged with HCFC-22 must be flushed.

Model Number Identification

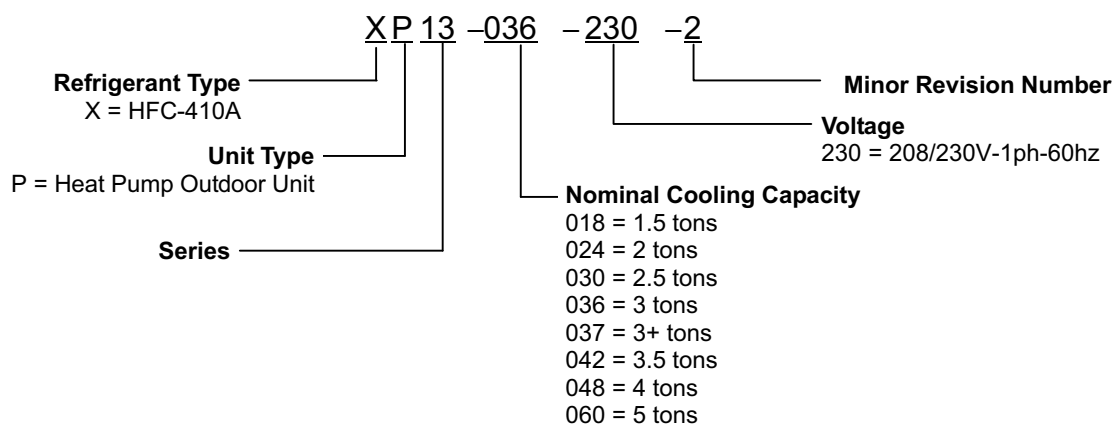

Typical Serial Number Identification

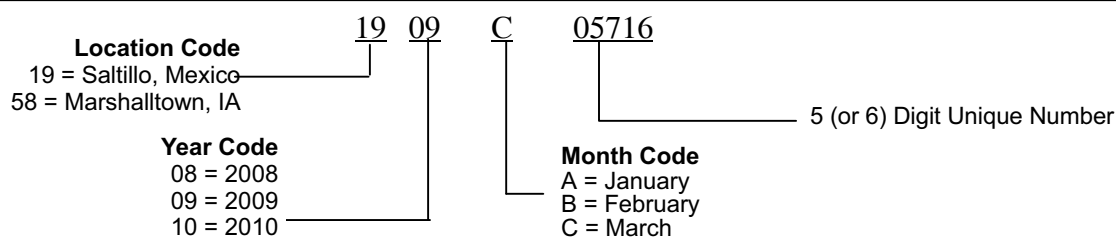

Specifications

Model Number	Unit		Outdoor Fan	
	Sound Rating Number (dB) ¹	Factory Refrigerant Charge ²	Number of Blades	Diameter - inches.
XP13-018-230-01	74	8 lbs. 15 oz.	3	18
XP13-018-230-03	74	8 lbs. 14 oz.	3	18
XP13-018-230-04	74	8 lbs. 14 oz.	3	18
XP13-018-230-05	74	8 lbs. 14 oz.	3	18

Model Number	Unit		Outdoor Fan	
	Sound Rating Number (dB) ¹	Factory Refrigerant Charge ²	Number of Blades	Diameter - inches.
XP13-024-230-01	74	7 lbs. 7 oz.	3	18
XP13-024-230-02	74	7 lbs. 13 oz.	3	18
XP13-024-230-03	74	7 lbs. 12 oz.	3	18
XP13-024-230-04	74	7 lbs. 12 oz.	3	18
XP13-024-230-05	74	7 lbs. 12 oz.	3	18

Model Number	Unit		Outdoor Fan	
	Sound Rating Number (dB) ¹	Factory Refrigerant Charge ²	Number of Blades	Diameter - inches.
XP13-030-230-01	76	7 lbs. 10 oz.	3	18
XP13-030-230-02	76	7 lbs. 10 oz.	3	18
XP13-030-230-03	76	6 lbs. 15 oz.	3	18
XP13-030-230-04	76	6 lbs. 15 oz.	3	18
XP13-030-230-05	76	6 lbs. 15 oz.	3	18

Model Number	Unit		Outdoor Fan	
	Sound Rating Number (dB) ¹	Factory Refrigerant Charge ²	Number of Blades	Diameter - inches.
XP13-036-230-01	76	10 lbs. 2 oz.	3	18
XP13-036-230-02	76	10 lbs. 2 oz.	3	18
XP13-036-230-03	76	8 lbs. 0 oz.	3	18
XP13-036-230-04	76	8 lbs. 0 oz.	3	18
XP13-036-230-05	76	8 lbs. 0 oz.	3	18

Model Number	Unit		Outdoor Fan	
	Sound Rating Number (dB) ¹	Factory Refrigerant Charge ²	Number of Blades	Diameter - inches.
XP13-037-230-01	74	10 lbs. 3 oz.	4	22
XP13-037-230-02	74	10 lbs. 3 oz.	4	22
XP13-037-230-03	74	10 lbs. 2 oz.	4	22

Model Number	Unit		Outdoor Fan	
	Sound Rating Number (dB) ¹	Factory Refrigerant Charge ²	Number of Blades	Diameter - inches.
XP13-042-230-01	76	11 lbs. 10 oz.	4	22
XP13-042-230-02	76	11 lbs. 10 oz.	4	22
XP13-042-230-03	76	10 lbs. 8 oz.	4	22
XP13-042-230-04	76	10 lbs. 8 oz.	4	22
XP13-042-230-05	76	10 lbs. 8 oz.	4	22

Model Number	Unit		Outdoor Fan	
	Sound Rating Number (dB) ¹	Factory Refrigerant Charge ²	Number of Blades	Diameter - inches.
XP13-048-230-01	76	11 lbs. 10 oz.	4	22
XP13-048-230-02	76	11 lbs. 10 oz.	4	22
XP13-048-230-03	76	11 lbs. 2 oz.	4	22
XP13-048-230-04	76	11 lbs. 2 oz.	4	22
XP13-048-230-05	76	11 lbs. 2 oz.	4	22

Model Number	Unit		Outdoor Fan	
	Sound Rating Number (dB) ¹	Factory Refrigerant Charge ²	Number of Blades	Diameter - inches.
XP13-060-230-01	76	15 lbs. 0 oz.	4	22
XP13-060-230-02	76	15 lbs. 0 oz.	4	22
XP13-060-230-03	76	11 lbs. 13 oz.	4	22
XP13-060-230-04	76	11 lbs. 13 oz.	4	22
XP13-060-230-05	76	11 lbs. 13 oz.	4	22

¹ Tested according to AHRI Standard 270-2008 test conditions.

² Refrigerant charge sufficient for 15 feet length of refrigerant lines.

Electrical Data

208/230V-60 Hz-1 Ph

Model Number	Unit		Compressor		Condenser Fan			
	Maximum Over-current Protection (amps) ¹	Minimum Circuitry Ampacity ²	Rated Load Amps (RLA)	Locked Rotor Amps (LRA)	Motor HP	Nominal RPM	Full Load Amps (FLA)	Locked Rotor Amps (LRA)
XP13-018-230-01	20	11.9	8.97	48.0	1/10	1075	0.7	1.4
XP13-018-230-03	20	11.9	8.97	48.0	1/10	1075	0.7	1.4
XP13-018-230-04	20	11.9	8.97	48.0	1/10	1075	0.7	1.4
XP13-018-230-05	20	11.9	8.97	48.0	1/10	1075	0.7	1.4

208/230V-60 Hz-1 Ph

Model Number	Unit		Compressor		Condenser Fan			
	Maximum Over-current Protection (amps) ¹	Minimum Circuitry Ampacity ²	Rated Load Amps (RLA)	Locked Rotor Amps (LRA)	Motor HP	Nominal RPM	Full Load Amps (FLA)	Locked Rotor Amps (LRA)
XP13-024-230-01	30	17.5	13.46	58.0	1/10	1075	0.7	1.4
XP13-024-230-02	30	17.5	13.46	58.0	1/10	1075	0.7	1.4
XP13-024-230-03	30	17.5	13.46	58.0	1/10	1075	0.7	1.4
XP13-024-230-04	30	17.5	13.46	58.0	1/10	1075	0.7	1.4
XP13-024-230-05	30	17.5	13.46	58.0	1/10	1075	0.7	1.4

208/230V-60 Hz-1 Ph

Model Number	Unit		Compressor		Condenser Fan			
	Maximum Over-current Protection (amps) ¹	Minimum Circuitry Ampacity ²	Rated Load Amps (RLA)	Locked Rotor Amps (LRA)	Motor HP	Nominal RPM	Full Load Amps (FLA)	Locked Rotor Amps (LRA)
XP13-036-230-01	35	21.9	16.67	79.0	1/5	1075	1.1	2.0
XP13-036-230-02	35	21.9	16.67	79.0	1/5	1075	1.1	2.0
XP13-036-230-03	35	21.9	16.67	79.0	1/5	1075	1.1	2.0
XP13-036-230-04	35	21.6	16.67	79.0	1/10	1075	0.7	1.4
XP13-036-230-05	35	21.6	16.67	70.0	1/10	1075	0.7	1.4

208/230V-60 Hz-1 Ph

Model Number	Unit		Compressor		Condenser Fan			
	Maximum Over-current Protection (amps) ¹	Minimum Circuitry Ampacity ²	Rated Load Amps (RLA)	Locked Rotor Amps (LRA)	Motor HP	Nominal RPM	Full Load Amps (FLA)	Locked Rotor Amps (LRA)
XP13-037-230-01	35	21.9	16.67	79.0	1/6	825	1.1	2.1
XP13-037-230-02	35	21.9	16.67	79.0	1/6	825	1.1	2.1
XP13-037-230-03	35	21.9	16.67	79.0	1/6	825	1.1	2.1

208/230V-60 Hz-1 Ph

Model Number	Unit		Compressor		Condenser Fan			
	Maximum Over-current Protection (amps) ¹	Minimum Circuitry Ampacity ²	Rated Load Amps (RLA)	Locked Rotor Amps (LRA)	Motor HP	Nominal RPM	Full Load Amps (FLA)	Locked Rotor Amps (LRA)
XP13-042-230-01	40	23.2	17.69	107.0	1/6	825	1.1	2.1
XP13-042-230-02	40	23.2	17.69	107.0	1/6	825	1.1	2.1
XP13-042-230-03	40	23.2	17.69	107.0	1/6	825	1.1	2.1
XP13-042-230-04	40	24.7	18.8	107.0	1/6	825	1.1	1.87
XP13-042-230-05	40	24.7	18.8	90.0	1/6	825	1.1	1.87

208/230V-60 Hz-1 Ph

Model Number	Unit		Compressor		Condenser Fan			
	Maximum Over-current Protection (amps) ¹	Minimum Circuitry Ampacity ²	Rated Load Amps (RLA)	Locked Rotor Amps (LRA)	Motor HP	Nominal RPM	Full Load Amps (FLA)	Locked Rotor Amps (LRA)
XP13-048-230-01	50	28.9	21.79	117.0	1/4	825	1.7	2.1
XP13-048-230-02	50	28.9	21.79	117.0	1/4	825	1.7	2.1
XP13-048-230-03	50	28.9	21.79	117.0	1/4	825	1.7	2.1
XP13-048-230-04	50	28.9	21.79	117.0	1/4	825	1.7	1.87
XP13-048-230-05	50	28.9	21.79	100.0	1/4	825	1.7	1.87

208/230V-60 Hz-1 Ph

Model Number	Unit		Compressor		Condenser Fan			
	Maximum Over-current Protection (amps) ¹	Minimum Circuitry Ampacity ²	Rated Load Amps (RLA)	Locked Rotor Amps (LRA)	Motor HP	Nominal RPM	Full Load Amps (FLA)	Locked Rotor Amps (LRA)
XP13-060-230-01	60	34.6	26.28	134.0	1/4	825	1.7	3.1
XP13-060-230-02	60	34.6	26.28	134.0	1/4	825	1.7	3.1
XP13-060-230-03	60	34.6	26.28	134.0	1/4	825	1.7	3.1
XP13-060-230-04	60	34.6	26.28	134.0	1/4	825	1.7	3.1
XP13-060-230-05	60	34.6	26.28	134.0	1/4	825	1.7	3.1

¹ HACR type circuit breaker or fuse.

² Refer to National or Canadian Electrical Code manual to determine wire, fuse and disconnect size requirements.

Unit Dimensions - Inches (mm)

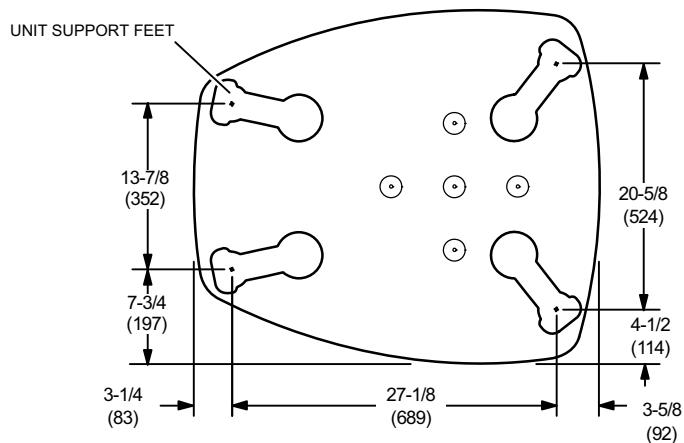
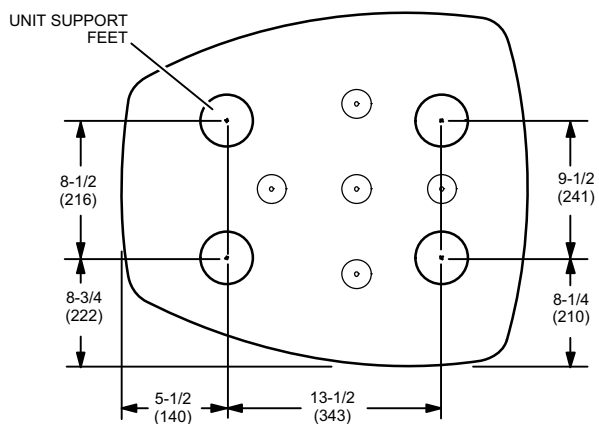
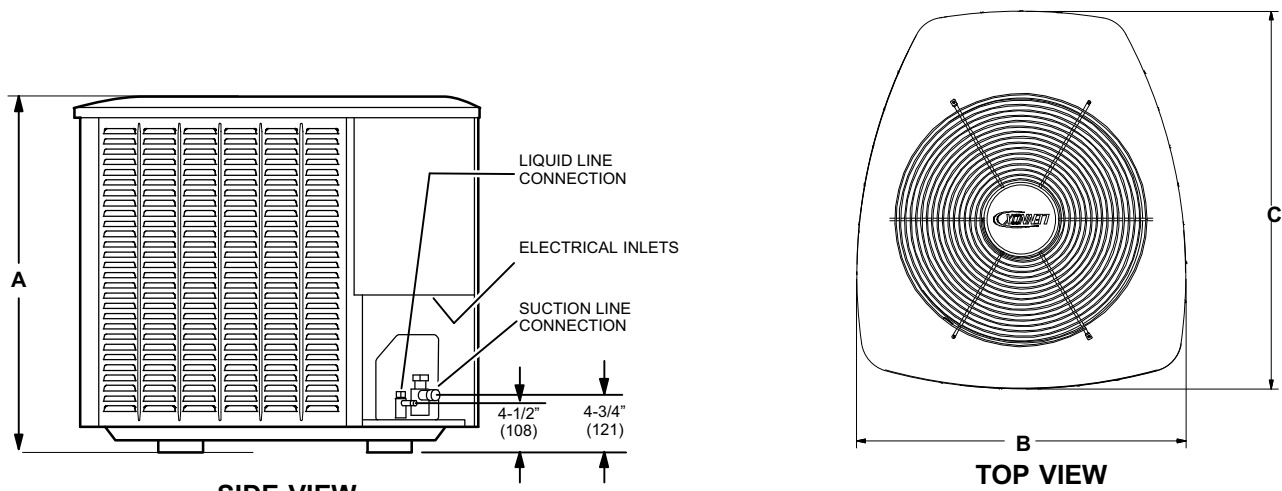

XP13-018, 024, 030 AND 036 BASE SECTION

XP13 BASE WITH ELONGATED LEGS

XP13	A	B	C
-018 (All)	31 (787)	27 (686)	28 (711)
-024 (All)	31 (787)	27 (686)	28 (711)
-030 (All)	31 (787)	27 (686)	28 (711)
-036 (All)	35 (889)	27 (686)	28 (711)
-037, -042, -048 (All)	35 (889)	30-1/2 (775)	35 (889)
-060 (All)	45 (1143)	30-1/2 (775)	35 (889)

Typical Unit Parts Arrangement

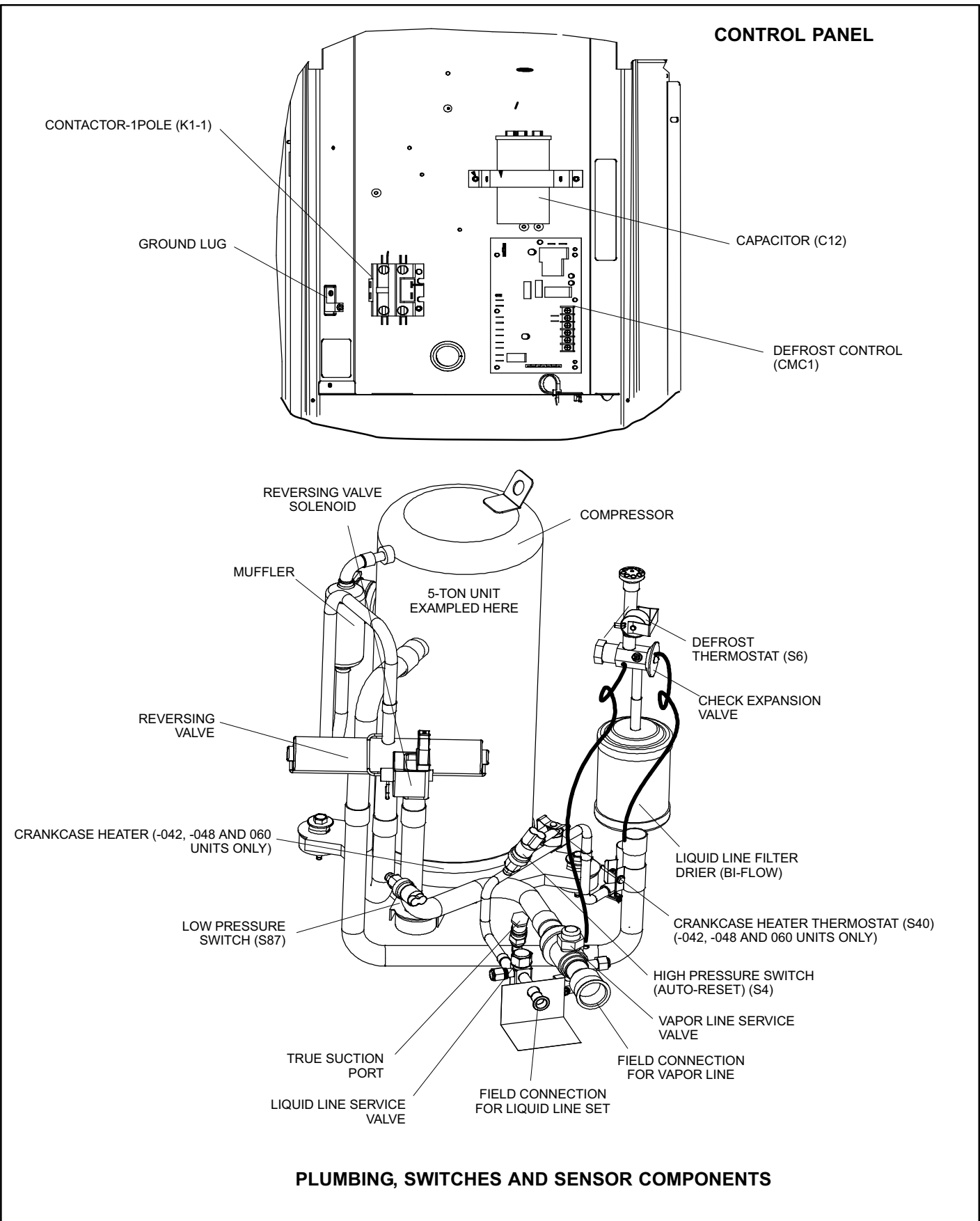

Figure 1. Typical Parts Arrangements

WARNING

This product and/or the indoor unit it is matched with may contain fiberglass wool.

Disturbing the insulation during installation, maintenance, or repair will expose you to fiberglass wool dust. Breathing this may cause lung cancer. (Fiberglass wool is known to the State of California to cause cancer.)

Fiberglass wool may also cause respiratory, skin, and eye irritation.

To reduce exposure to this substance or for further information, consult material safety data sheets available from address shown below, or contact your supervisor.

Lennox Industries Inc.
P.O. Box 799900
Dallas, TX 75379-9900

IMPORTANT

Only use Allen wrenches of sufficient hardness (50Rc - Rockwell Harness Scale minimum). Fully insert the wrench into the valve stem recess.

Service valve stems are factory-torqued (from 9 ft-lbs for small valves, to 25 ft-lbs for large valves) to prevent refrigerant loss during shipping and handling. Using an Allen wrench rated at less than 50Rc risks rounding or breaking off the wrench, or stripping the valve stem recess.

See the Lennox Service and Application Notes #C-08-1 for further details and information.

IMPORTANT

To prevent stripping of the various caps used, the appropriately sized wrench should be used and fitted snugly over the cap before tightening.

WARNING



Electric Shock Hazard. Can cause injury or death. Unit must be grounded in accordance with national and local codes.

Line voltage is present at all components when unit is not in operation on units with single-pole contactors. Disconnect all remote electric power supplies before opening access panel. Unit may have multiple power supplies.

Table 1. Torque Requirements

Parts	Recommended Torque	
Service valve cap	8 ft.- lb.	11 NM
Sheet metal screws	16 in.- lb.	2 NM
Machine screws #10	28 in.- lb.	3 NM
Compressor bolts	90 in.- lb.	10 NM
Gauge port seal cap	8 ft.- lb.	11 NM

USING MANIFOLD GAUGE SET

When checking the system charge, only use a manifold gauge set that features low loss anti-blow back fittings.

Manifold gauge set used with HFC-410A refrigerant systems must be capable of handling the higher system operating pressures. The gauges should be rated for use with pressures of 0 - 800 psig on the high side and a low side of 30" vacuum to 250 psig with dampened speed to 500 psi. Gauge hoses must be rated for use at up to 800 psig of pressure with a 4000 psig burst rating.

OPERATING SERVICE VALVES

The liquid and vapor line service valves are used for removing refrigerant, flushing, leak testing, evacuating, checking charge and charging.

Each valve is equipped with a service port which has a factory-installed valve stem. Figure 2 provides information on how to access and operating both angle and ball service valves.

Operating Gauge Set and Service Valves

These instructions are intended as a general guide and do not supersede local codes in any way. Consult authorities who have jurisdiction before installation.

TORQUE REQUIREMENTS

When servicing or repairing heating, ventilating, and air conditioning components, ensure the fasteners are appropriately tightened. Table 1 lists torque values for fasteners.

SERVICE VALVES

VARIOUS TYPES

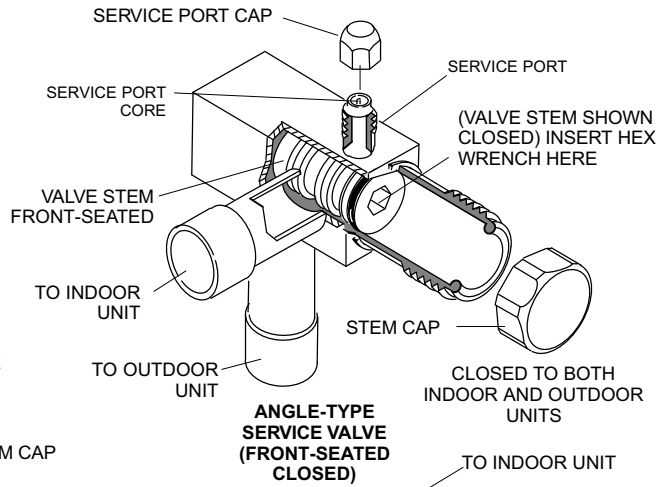
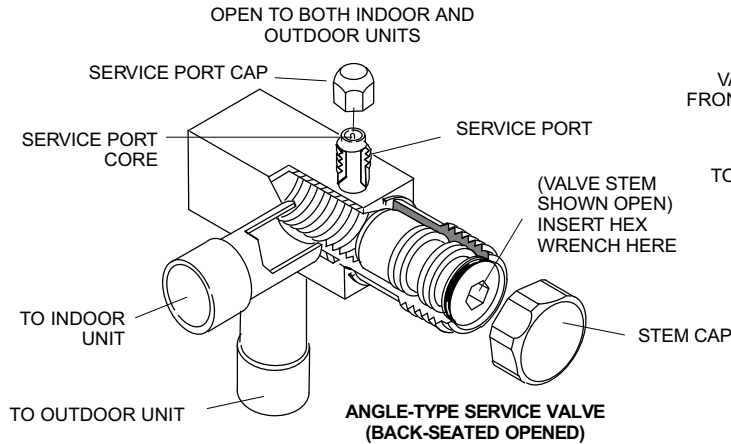

WHEN SERVICE VALVE IS CLOSED, THE SERVICE PORT IS OPEN TO THE LINE SET AND INDOOR UNIT.

WHEN SERVICE VALVE IS OPEN, THE SERVICE PORT IS OPEN TO LINE SET, INDOOR AND OUTDOOR UNIT.

TO OPEN ROTATE STEM COUNTERCLOCKWISE 90°.

TO CLOSE ROTATE STEM CLOCKWISE 90°.

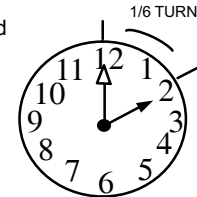
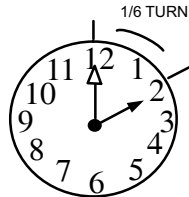
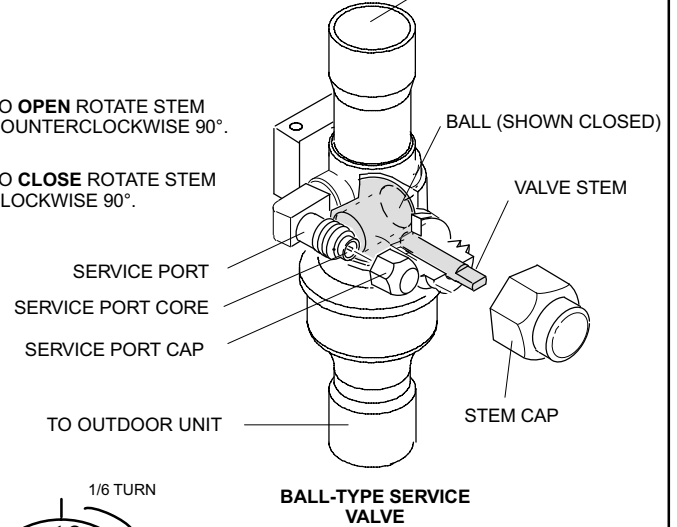

To Access Service Port:

A service port cap protects the service port core from contamination and serves as the primary leak seal.

1. Remove service port cap with an appropriately sized wrench.
2. Connect gauge set to service port.
3. When testing is completed, replace service port cap and tighten as follows:
 - With Torque Wrench: Finger tighten and torque cap per table 1.
 - Without Torque Wrench: Finger tighten and use an appropriately sized wrench to turn an additional 1/6 turn clockwise.

Operating Angle Type Service Valve:

1. Remove stem cap with an appropriately sized wrench.
2. Use a service wrench with a hex-head extension (3/16" for liquid line valve sizes and 5/16" for vapor line valve sizes) to back the stem out counterclockwise as far as it will go.

Operating Ball Type Service Valve:

1. Remove stem cap with an appropriately sized wrench.
2. Use an appropriately sized wrench to open. To open valve, rotate stem counterclockwise 90°. To close rotate stem clockwise 90°.

Reinstall Stem Cap:

Stem cap protects the valve stem from damage and serves as the primary seal. Replace the stem cap and tighten as follows:

- With Torque Wrench: Finger tighten and then torque cap per table 1.
- Without Torque Wrench: Finger tighten and use an appropriately sized wrench to turn an additional 1/12 turn clockwise.

NOTE — A label with specific torque requirements may be affixed to the stem cap. If the label is present, use the specified torque.

Figure 2. Angle and Ball Service Valves

Recovering Refrigerant from System

1 DISCONNECT POWER

Disconnect all power to the existing outdoor unit at the disconnect switch or main fuse box/breaker panel.

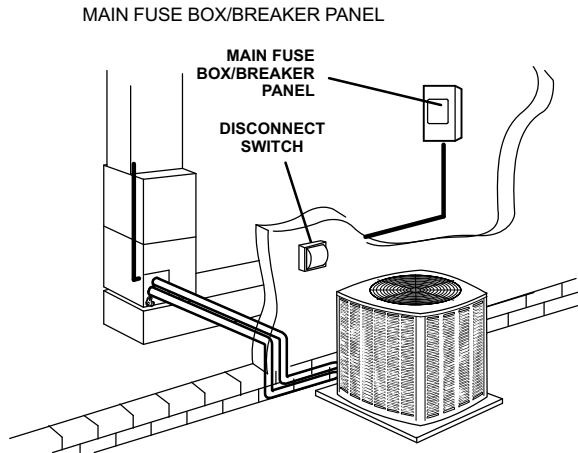

2 CONNECT MANIFOLD GAUGE SET

Connect a gauge set, clean recovery cylinder and a recovery machine to the service ports of the existing unit. Use the instructions provided with the recovery machine to make the connections.

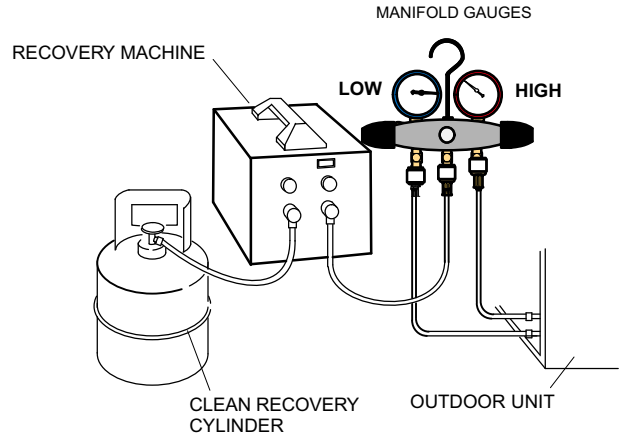

3 RECOVERING REFRIGERANT

Remove existing HCFC-22 refrigerant using one of the following procedures:

IMPORTANT — Some system configurations may contain higher than normal refrigerant charge due to either large internal coil volumes, and/or long line sets.

METHOD 1:

Use this method if the existing outdoor unit is not equipped with shut-off valves, or if the unit is not operational and you plan to use the existing HCFC-22 to flush the system.

Remove all HCFC-22 refrigerant from the existing system. Check gauges after shutdown to confirm that the entire system is completely void of refrigerant.

METHOD 2:

Use this method if the existing outdoor unit is equipped with manual shut-off valves, and you plan to use new HCFC-22 refrigerant to flush the system.

The following devices could prevent full system charge recovery into the outdoor unit:

- Outdoor unit's high or low-pressure switches (if applicable) when tripped can cycle the compressor **OFF**.
- Compressor can stop pumping due to tripped internal pressure relief valve.
- Compressor has internal vacuum protection that is designed to unload the scrolls (compressor stops pumping) when the pressure ratio meets a certain value or when the suction pressure is as high as 20 psig. (Compressor suction pressures should never be allowed to go into a vacuum. Prolonged operation at low suction pressures will result in overheating of the scrolls and permanent damage to the scroll tips, drive bearings and internal seals.)

Once the compressor can not pump down to a lower pressure due to one of the above system conditions, shut off the vapor valve. Turn OFF the main power to unit and use a recovery machine to recover any refrigerant left in the indoor coil and line set.

Perform the following task:

- A Start the existing HCFC-22 system in the cooling mode and close the liquid line valve.
- B Use the compressor to pump as much of the existing HCFC-22 refrigerant into the outdoor unit until the outdoor system is full. Turn the outdoor unit main power OFF and use a recovery machine to remove the remaining refrigerant from the system.

NOTE — It may be necessary to bypass the low pressure switches (if equipped) to ensure complete refrigerant evacuation.

- C When the low side system pressures reach 0 psig, close the vapor line valve.
- D Check gauges after shutdown to confirm that the valves are not allowing refrigerant to flow back into the low side of the system.

Figure 3. Refrigerant Recovery

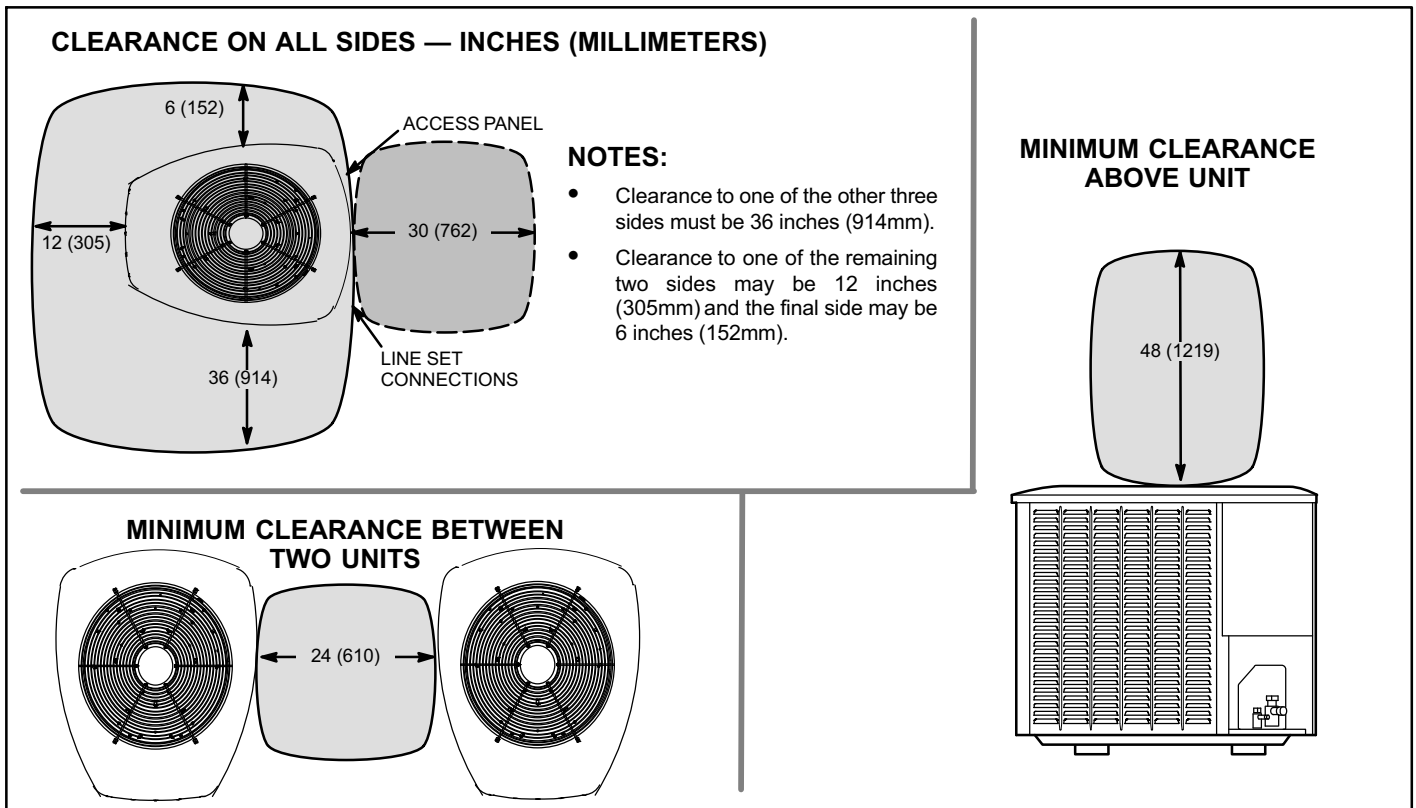

Figure 4. Installation Clearances

Unit Placement

⚠ CAUTION

In order to avoid injury, take proper precaution when lifting heavy objects.

See *Unit Dimensions* on page 3 for sizing mounting slab, platforms or supports. Refer to figure 4 for mandatory installation clearance requirements.

POSITIONING CONSIDERATIONS

Consider the following when positioning the unit:

- Some localities are adopting sound ordinances based on the unit's sound level registered from the adjacent property, not from the installation property. Install the unit as far as possible from the property line.
- When possible, do not install the unit directly outside a window. Glass has a very high level of sound transmission. For proper placement of unit in relation to a window see the provided illustration in figure 5, detail A.

PLACING UNIT ON SLAB

When installing unit at grade level, the top of the slab should be high enough above grade so that water from higher ground will not collect around the unit. The slab should have a slope tolerance as described in figure 5, detail B.

NOTE — If necessary for stability, anchor unit to slab as described in figure 5, detail D.

ELEVATING THE UNIT

Units are outfitted with elongated support feet as illustrated in figure 5, detail C.

If additional elevation is necessary, raise the unit by extending the height of the unit support feet. This may be achieved by using a 2 inch (50.8mm) Schedule 40 female threaded adapter.

The specified coupling will fit snugly into the recessed portion of the feet. Use additional 2 inch (50.8mm) Schedule 40 male threaded adaptors which can be threaded into the female threaded adaptors to make additional adjustments to the level of the unit.

NOTE — Keep the height of extenders short enough to ensure a sturdy installation. If it is necessary to extend further, consider a different type of field-fabricated framework that is sturdy enough for greater heights.

DETAIL A— Outside Unit Placement

Install unit away from windows.

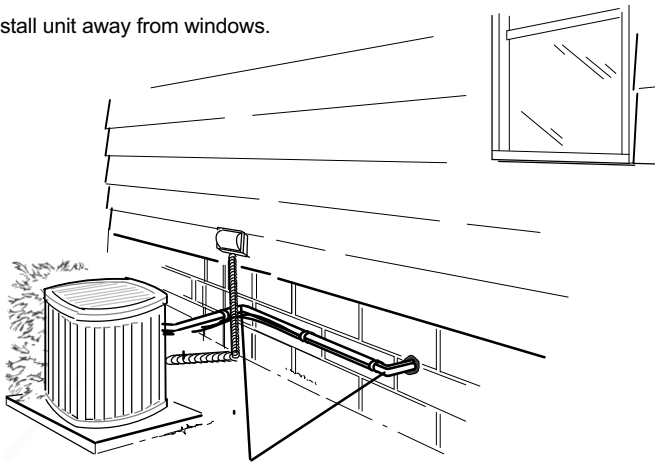

TWO 90° ELBOWS INSTALLED IN LINE SET WILL REDUCE LINE SET VIBRATION.

DETAIL B— Slab Mounting at Ground Level

Install unit level or, if on a slope, maintain slope tolerance of two (2) degrees (or two inches per five feet [50 mm per 1.5 m]) away from building structure.

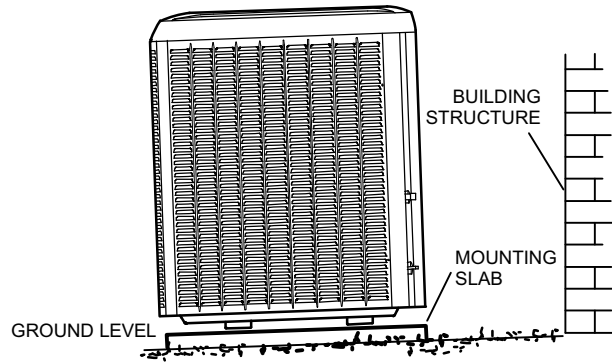

DETAIL C— Elevated Slab Mounting using Feet Extenders

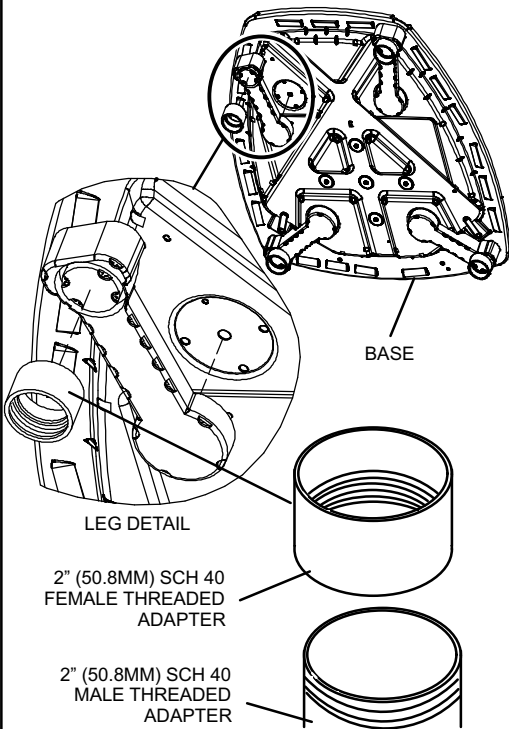

Use additional 2" SCH 40 male threaded adapters which can be threaded into the female threaded adapters to make additional adjustments to the level of the unit.

STABILIZING UNIT ON UNEVEN SURFACES

DETAIL D— Slab Side Mounting

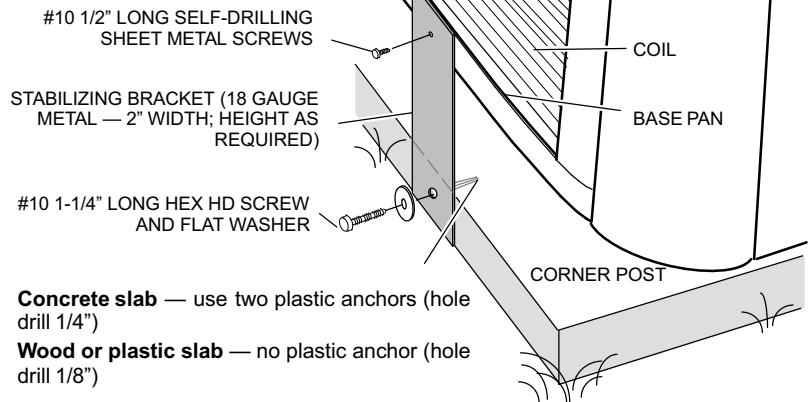

Concrete slab — use two plastic anchors (hole drill 1/4")

Wood or plastic slab — no plastic anchor (hole drill 1/8")

DETAIL E— Deck Top Mounting

Stabilizing bracket (18 gauge metal — 2" (50.8mm) width; height as required); bend to form right angle as exemplified below.

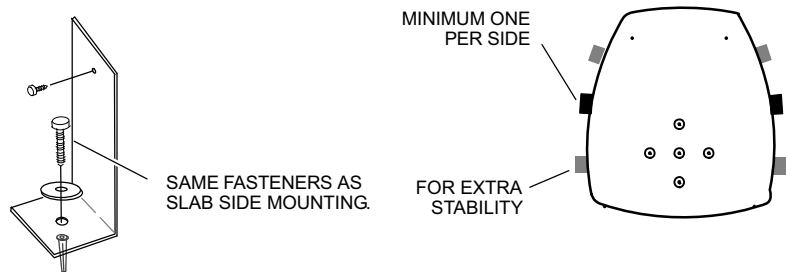

One bracket per side (minimum). For extra stability, two brackets per side, two inches (51mm) from each corner.

IMPORTANT — To help stabilize an outdoor unit, some installations may require strapping the unit to the pad using brackets and anchors commonly available in the marketplace.

Figure 5. Placement, Slab Mounting and Stabilizing Unit

STABILIZING UNIT ON UNEVEN SURFACES

IMPORTANT

Unit Stabilizer Bracket Use (field-provided):

Always use stabilizers when unit is raised above the factory height. (Elevated units could become unstable in gusty wind conditions).

Stabilizers may be used on factory height units when mounted on unstable an uneven surface.

With unit positioned at installation site, perform the following:

1. Remove two side louvered panels to expose the unit base.
2. Install the brackets as illustrated in figure 5, detail D or E using conventional practices.
3. Replace the panels after installation is complete.

ROOF MOUNTING

Install the unit a minimum of 6 inches (152 mm) above the roof surface to avoid ice build-up around the unit. Locate the unit above a load bearing wall or area of the roof that can adequately support the unit. Consult local codes for rooftop applications.

If unit coil cannot be mounted away from prevailing winter winds, a wind barrier should be constructed. Size barrier at least the same height and width as outdoor unit. Mount barrier 24 inches (610 mm) from the sides of the unit in the direction of prevailing winds.

NOTICE

Roof Damage!

This system contains both refrigerant and oil. Some rubber roofing material may absorb oil and cause the rubber to swell when it comes into contact with oil. The rubber will then bubble and could cause leaks. Protect the roof surface to avoid exposure to refrigerant and oil during service and installation. Failure to follow this notice could result in damage to roof surface.

Removing and Installing Panels

IMPORTANT

Do not allow panels to hang on unit by top tab. Tab is for alignment and not designed to support weight of panel.

IMPORTANT

To help stabilize an outdoor unit, some installations may require strapping the unit to the pad using brackets and anchors commonly available in the marketplace.

WARNING

To prevent personal injury, or damage to panels, unit or structure, be sure to observe the following:

While installing or servicing this unit, carefully stow all removed panels out of the way, so that the panels will not cause injury to personnel, nor cause damage to objects or structures nearby, nor will the panels be subjected to damage (e.g., being bent or scratched).

While handling or stowing the panels, consider any weather conditions, especially windy conditions, that may cause panels to be blown around and battered.

LOUVERED PANEL REMOVAL

Remove the louvered panels as follows:

1. Remove two screws, allowing the panel to swing open slightly.
2. Hold the panel firmly throughout this procedure. Rotate bottom corner of panel away from hinged corner post until lower three tabs clear the slots as illustrated in **detail B**.
3. Move panel down until lip of upper tab clears the top slot in corner post as illustrated in **detail A**.

LOUVERED PANEL INSTALLATION

Position the panel almost parallel with the unit as illustrated in **detail D** with the screw side as close to the unit as possible.

Then, in a continuous motion:

1. Slightly rotate and guide the lip of top tab inward as illustrated in **detail A** and **C**; then upward into the top slot of the hinge corner post.
2. Rotate panel to vertical to fully engage all tabs.
3. Holding the panel's hinged side firmly in place, close the right-hand side of the panel, aligning the screw holes.
4. When panel is correctly positioned and aligned, insert the screws and tighten.

Detail C

MAINTAIN MINIMUM PANEL ANGLE (AS CLOSE TO PARALLEL WITH THE UNIT AS POSSIBLE) WHILE INSTALLING PANEL.

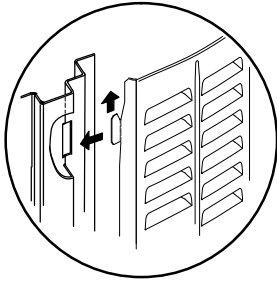

IMPORTANT! DO NOT ALLOW PANELS TO HANG ON UNIT BY TOP TAB. TAB IS FOR ALIGNMENT AND NOT DESIGNED TO SUPPORT WEIGHT OF PANEL.

PANEL SHOWN SLIGHTLY ROTATED TO ALLOW TOP TAB TO EXIT (OR ENTER) TOP SLOT FOR REMOVING (OR INSTALLING) PANEL.

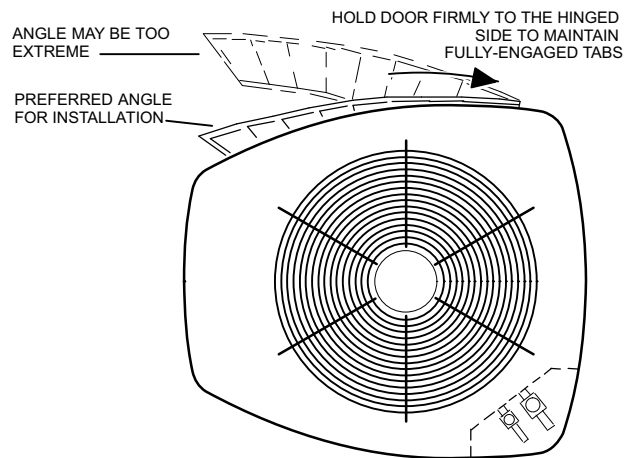
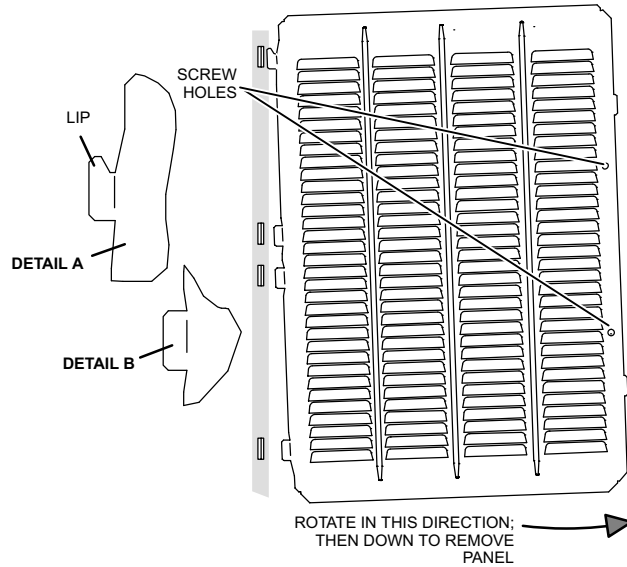

Figure 6. Removing and Installing Panels

New or Replacement Line Set

REFRIGERANT LINE SET

This section provides information on installation or replacement of existing line set. If new or replacement line set is not being installed then proceed to *Brazing Connections* on page 17.

⚠ IMPORTANT

Lennox highly recommends changing line set when converting the existing system from HCFC-22 to HFC-410A. If that is not possible and the line set is the proper size as reference in table 2, use the procedure outlined under *Flushing the System* on page 13.

If refrigerant lines are routed through a wall, then seal and isolate the opening so vibration is not transmitted to the building. Pay close attention to line set isolation during installation of any HVAC system. When properly isolated from building structures (walls, ceilings, floors), the refrigerant lines will not create unnecessary vibration and subsequent sounds. See figure 7 for recommended installation practices. Also, consider the following when placing and installing a high-efficiency outdoor unit.

Liquid lines that meter the refrigerant, such as RFC1 liquid lines, must not be used in this application. Existing line set of proper size as listed in table 2 may be reused. If system was previously charged with HCFC-22 refrigerant, then existing line set must be flushed (see *Flushing the System* on page 20).

Field refrigerant piping consists of liquid and vapor lines from the outdoor unit to the indoor unit coil (braze connections). Use Lennox L15 (sweat, non-flare) series line set, or field-fabricated refrigerant line sizes as listed in table 2.

Table 2. Refrigerant Line Set — Inches (mm)

Model	Field Connections		Recommended Line Set		
	Liquid Line	Suction Line	Liquid Line	Suction Line	L15 Line Set
-018 -024 -030 -036	3/8" (10 mm)	3/4" (19 mm)	3/8" (10 mm)	3/4" (19 mm)	L15-41 15 ft. - 50 ft. (4.6 m - 15 m)
-037 -042 -048	3/8" (10 mm)	7/8" (22 mm)	3/8" (10 mm)	7/8" (22 mm)	L15-65 15 ft. - 50 ft. (4.6 m - 15 m)
-060	3/8" (10 mm)	1-1/8" (29 mm)	3/8" (10 mm)	1-1/8" (29 mm)	Field Fabricated

NOTE — When installing refrigerant lines longer than 50 feet, see the *Lennox Refrigerant Piping Design and Fabrication Guidelines, CORP. 9351-L9*, or contact *Lennox Technical Support Product Applications* for assistance.

To obtain the correct information from Lennox, be sure to communicate the following information:

- Model (XP13) and size of unit (e.g. -036).
- Line set diameters for the unit being installed as listed in table 2 and total length of installation.
- Number of elbows vertical rise or drop in the piping.

The compressor is charged with sufficient Polyol ester oil for line set lengths up to 50 feet. Recommend adding oil to system based on the amount of refrigerant charge in the system. No need to add oil in system with 20 pounds of refrigerant or less. For systems over 20 pounds - add one ounce of every five pounds of refrigerant.

Recommended topping-off POE oils are Mobil EAL ARCTIC 22 CC or ICI EMKARATE™ RL32CF.

⚠ WARNING

Polyol Ester (POE) oils used with HFC-410A refrigerant absorb moisture very quickly. It is very important that the refrigerant system be kept closed as much as possible. **DO NOT** remove line set caps or service valve stub caps until you are ready to make connections.

⚠ IMPORTANT

Mineral oils are not compatible with HFC-410A. If oil must be added, it must be a Polyol Ester oil.

Line Set Isolation — The following illustrations are examples of proper refrigerant line set isolation:

REFRIGERANT LINE SET — TRANSITION FROM VERTICAL TO HORIZONTAL

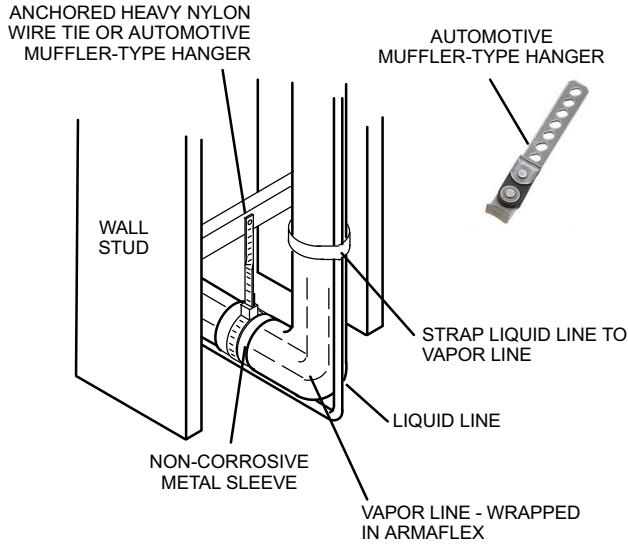

REFRIGERANT LINE SET — INSTALLING VERTICAL RUNS (NEW CONSTRUCTION SHOWN)

NOTE — Insulate liquid line when it is routed through areas where the surrounding ambient temperature could become higher than the temperature of the liquid line or when pressure drop is equal to or greater than 20 psig.

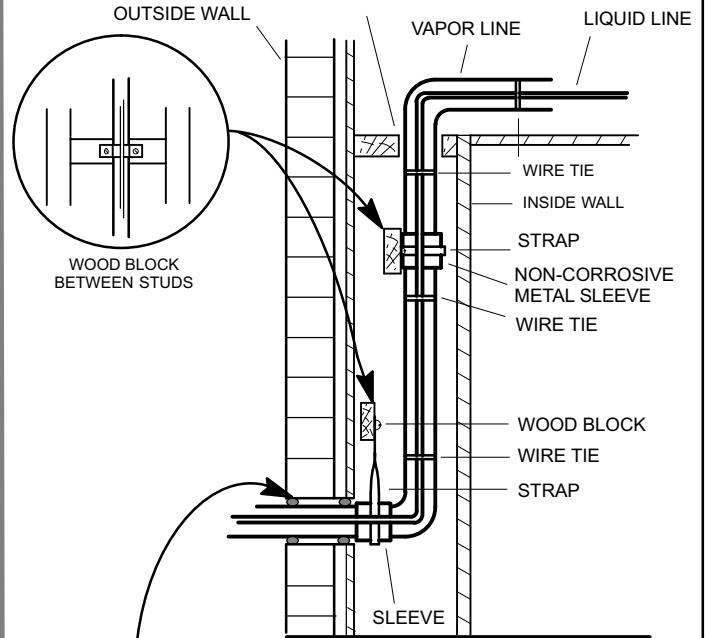

REFRIGERANT LINE SET — INSTALLING HORIZONTAL RUNS

To hang line set from joist or rafter, use either metal strapping material or anchored heavy nylon wire ties.

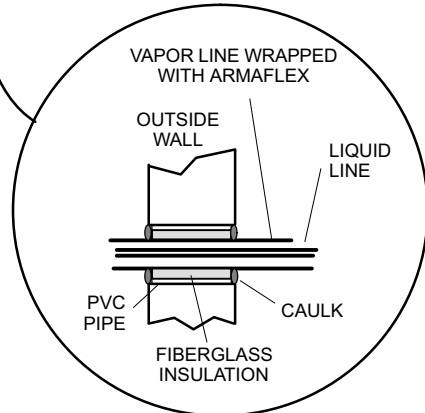
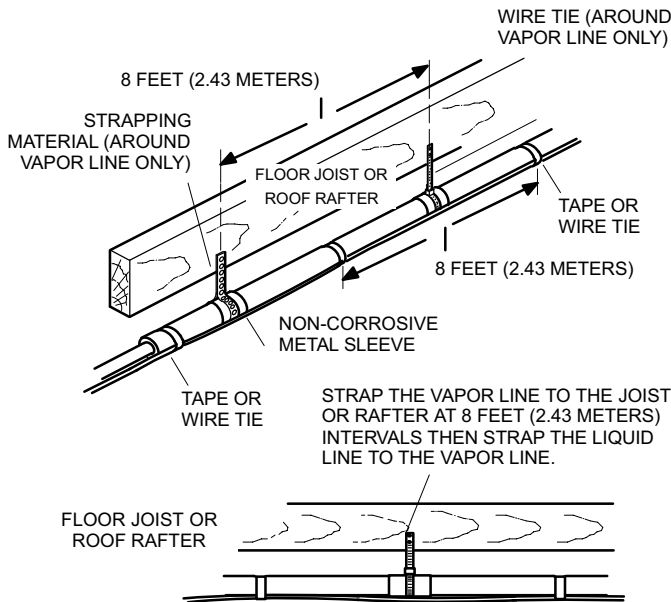

NOTE — Similar installation practices should be used if line set is to be installed on exterior of outside wall.

Figure 7. Line Set Installation

Brazing Connections

Use the procedures outline in figures 8 and 9 for brazing line set connections to service valves.

WARNING



Danger of fire. Bleeding the refrigerant charge from only the high side may result in pressurization of the low side shell and suction tubing. Application of a brazing torch to a pressurized system may result in ignition of the refrigerant and oil mixture - Check the high and low pressures before applying heat.

WARNING



When using a high pressure gas such as dry nitrogen to pressurize a refrigeration or air conditioning system, use a regulator that can control the pressure down to 1 or 2 psig (6.9 to 13.8 kPa).

CAUTION

Brazing alloys and flux contain materials which are hazardous to your health.

Avoid breathing vapors or fumes from brazing operations. Perform operations only in well-ventilated areas.

Wear gloves and protective goggles or face shield to protect against burns.

Wash hands with soap and water after handling brazing alloys and flux.

IMPORTANT

Connect gauge set low pressure side to vapor line service valve and repeat procedure starting at paragraph 4 for brazing the liquid line to service port valve.

IMPORTANT

Allow braze joint to cool before removing the wet rag from the service valve. Temperatures above 250°F can damage valve seals.

IMPORTANT

Use silver alloy brazing rods with 5% minimum silver alloy for copper-to-copper brazing. Use 45% minimum alloy for copper-to-brass and copper-to-steel brazing.

WARNING



Fire, Explosion and Personal Safety Hazard.

Failure to follow this warning could result in damage, personal injury or death.

Never use oxygen to pressurize or purge refrigeration lines. Oxygen, when exposed to a spark or open flame, can cause fire and/or an explosion, that could result in property damage, personal injury or death.

1 CUT AND DEBUR

Cut ends of the refrigerant lines square (free from nicks or dents) and debur the ends. The pipe must remain round. Do not crimp end of the line.

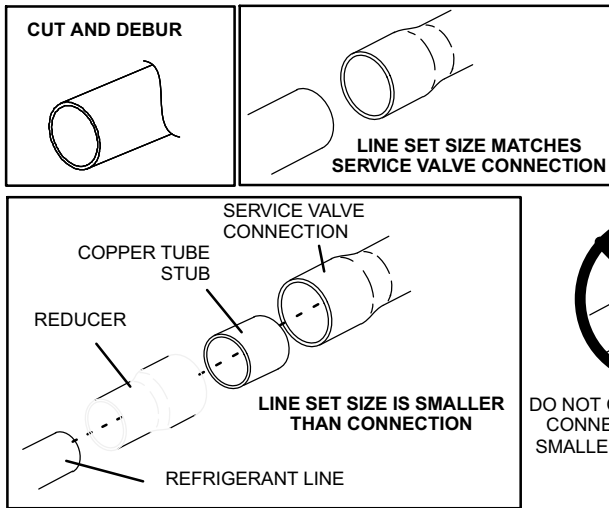

DO NOT CRIMP SERVICE VALVE CONNECTOR WHEN PIPE IS SMALLER THAN CONNECTION

2 CAP AND CORE REMOVAL

Remove service cap and core from both the suction / vapor and liquid line service ports.

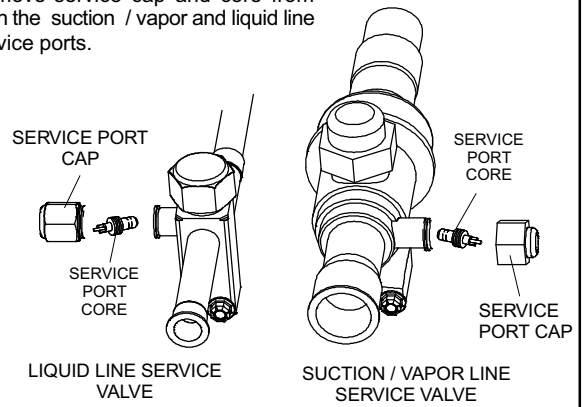

3 ATTACH THE MANIFOLD GAUGE SET FOR BRAZING LIQUID AND SUCTION / VAPOR LINE SERVICE VALVES

Flow regulated nitrogen (at 1 to 2 psig) through the low-side refrigeration gauge set into the liquid line service port valve, and out of the suction / vapor line service port valve.

- Connect gauge set low pressure side to liquid line service valve (service port).
- Connect gauge set center port to bottle of nitrogen with regulator.
- Remove core from valve in suction / vapor line service port to allow nitrogen to escape.

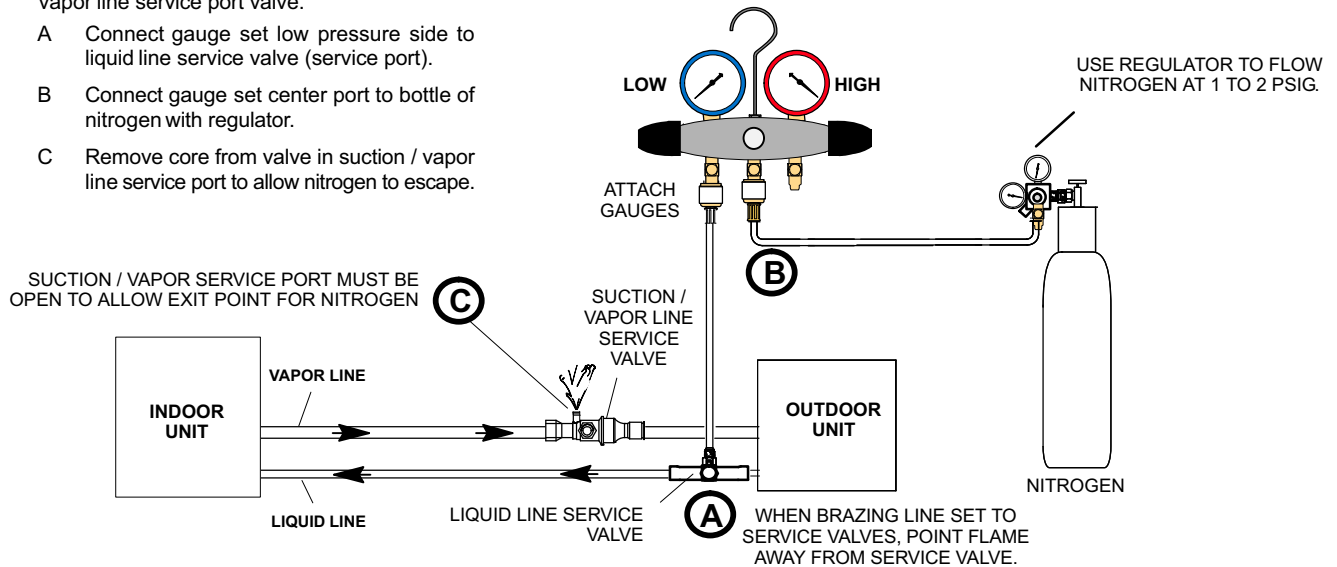

Figure 8. Brazing Procedures

4 WRAP SERVICE VALVES

To help protect service valve seals during brazing, wrap water saturated cloths around service valve bodies and copper tube stubs. Use additional water saturated cloths underneath the valve body to protect the base paint.

5 FLOW NITROGEN

Flow regulated nitrogen (at 1 to 2 psig) through the refrigeration gauge set into the valve stem port connection on the liquid service valve and out of the suction / vapor valve stem port. See steps **3A**, **3B** and **3C** on manifold gauge set connections

6 BRAZE LINE SET

Wrap both service valves with water saturated cloths as illustrated here and as mentioned in step 4, before brazing to line set. Water saturated cloths must remain water saturated throughout the brazing and cool-down process.

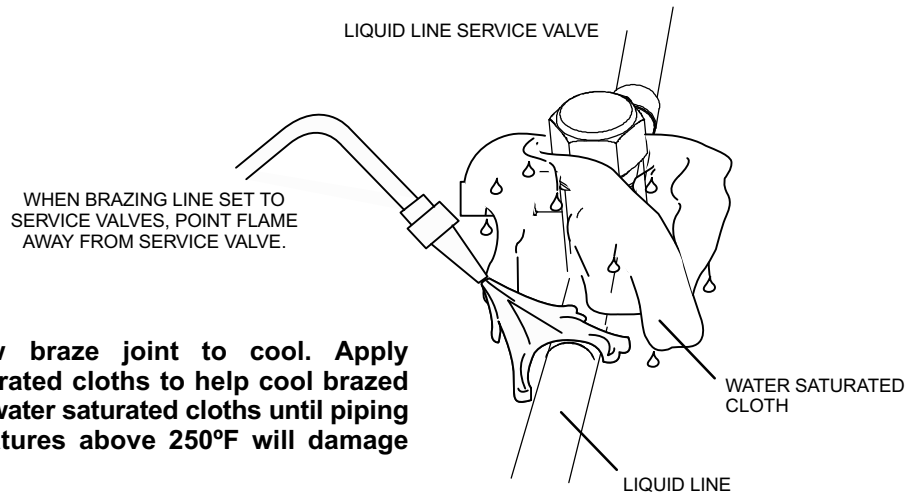

IMPORTANT — Allow braze joint to cool. Apply additional water saturated cloths to help cool brazed joint. Do not remove water saturated cloths until piping has cooled. Temperatures above 250°F will damage valve seals.

WARNING

- 1. FIRE, PERSONAL INJURY, OR PROPERTY DAMAGE** will result if you do not wrap a water saturated cloth around both liquid and suction line service valve bodies and copper tube stub while brazing in the line set! The braze, when complete, must be quenched with water to absorb any residual heat.
- 2. Do not open service valves until refrigerant lines and indoor coil have been leak-tested and evacuated. Refer to procedures provided in this supplement.**

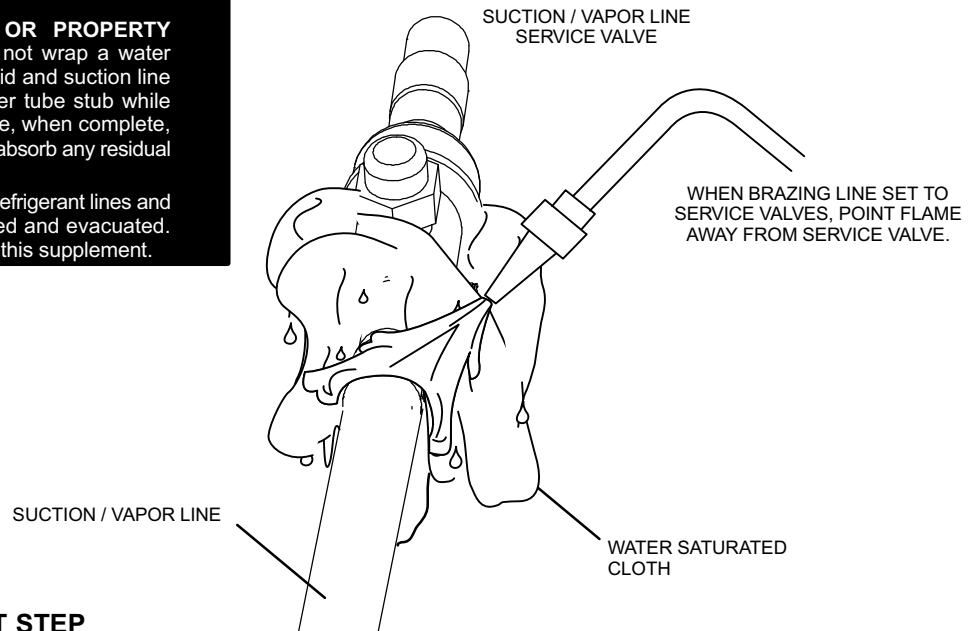

7 PREPARATION FOR NEXT STEP

After all connections have been brazed, disconnect manifold gauge set from service ports. Apply additional water saturated cloths to both services valves to cool piping. Once piping is cool, remove all water saturated cloths. Refer to the unit installation instructions for the next step in preparing the unit.

Figure 9. Brazing Procedures (continued)

Flushing Line Set and Indoor Coil

1A TYPICAL EXISTING FIXED ORIFICE REMOVAL PROCEDURE (UNCASED OR COIL SHOWN)

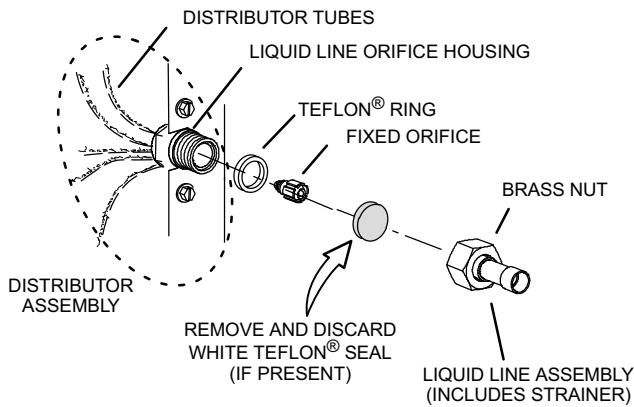

- On fully cased coils, remove the coil access and plumbing panels.
- Remove any shipping clamps holding the liquid line and distributor assembly.
- Using two wrenches, disconnect liquid line from liquid line orifice housing. Take care not to twist or damage distributor tubes during this process.
- Remove and discard fixed orifice, valve stem assembly if present and Teflon® washer as illustrated above.
- Use a field-provided fitting to temporary reconnect the liquid line to the indoor unit's liquid line orifice housing.

1B TYPICAL EXISTING EXPANSION VALVE REMOVAL PROCEDURE (UNCASED COIL SHOWN)

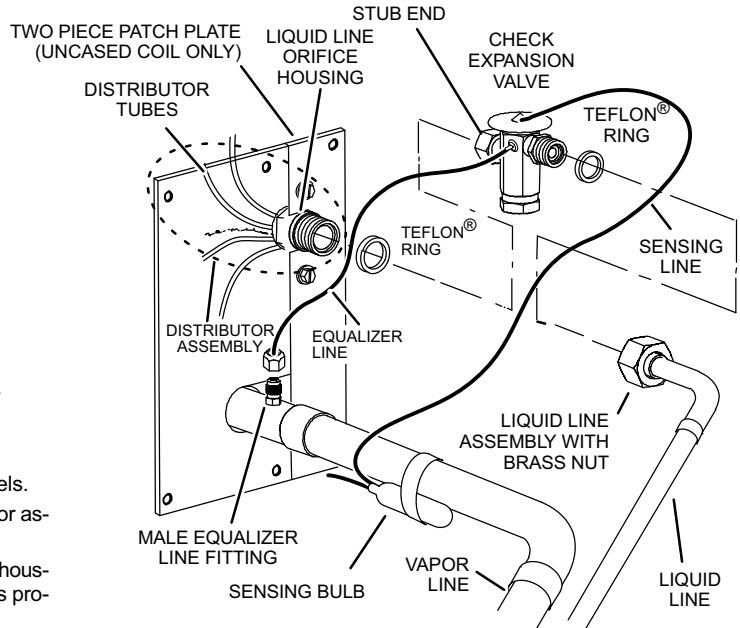

- On fully cased coils, remove the coil access and plumbing panels.
- Remove any shipping clamps holding the liquid line and distributor assembly.
- Disconnect the equalizer line from the check expansion valve equalizer line fitting on the vapor line.
- Remove the vapor line sensing bulb.
- Disconnect the liquid line from the check expansion valve at the liquid line assembly.
- Disconnect the check expansion valve from the liquid line orifice housing. Take care not to twist or damage distributor tubes during this process.
- Remove and discard check expansion valve and the two Teflon® rings.
- Use a field-provided fitting to temporary reconnect the liquid line to the indoor unit's liquid line orifice housing.

2 CONNECT GAUGES AND EQUIPMENT FOR FLUSHING PROCEDURE

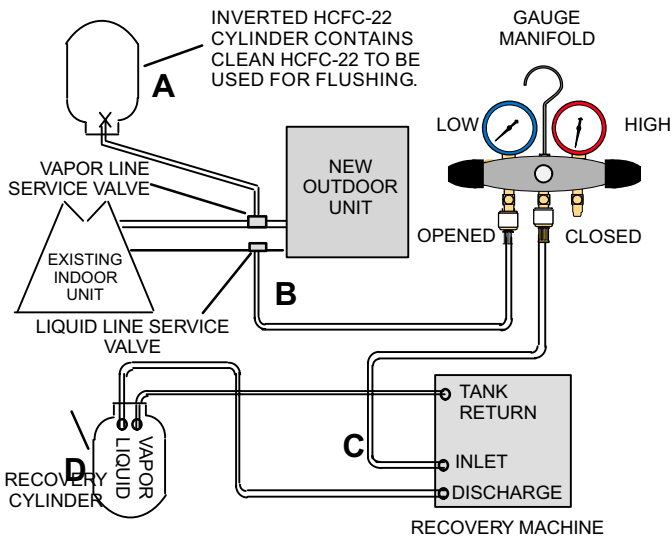

- Inverted HCFC-22 cylinder with clean refrigerant to the vapor service valve.
- HCFC-22 gauge set (low side) to the liquid line valve.
- HCFC-22 gauge set center port to inlet on the recovery machine with an empty recovery tank to the gauge set.
- Connect recovery tank to recovery machines per machine instructions.

3 FLUSHING LINE SET

The line set and indoor unit coil must be flushed with at least the same amount of clean refrigerant that previously charged the system. Check the charge in the flushing cylinder before proceeding.

- Set the recovery machine for liquid recovery and start the recovery machine. Open the gauge set valves to allow the recovery machine to pull a vacuum on the existing system line set and indoor unit coil.
- Invert the cylinder of clean HCFC-22 and open its valve to allow liquid refrigerant to flow into the system through the vapor line valve. Allow the refrigerant to pass from the cylinder and through the line set and the indoor unit coil before it enters the recovery machine.
- After all of the liquid refrigerant has been recovered, switch the recovery machine to vapor recovery so that all of the HCFC-22 vapor is recovered. Allow the recovery machine to pull down to 0 the system.
- Close the valve on the inverted HCFC-22 drum and the gauge set valves. Pump the remaining refrigerant out of the recovery machine and turn the machine off.

Figure 10. Installing Indoor Expansion Valve

Installing Indoor Metering Device

This outdoor unit is designed for use in systems that use check expansion valve metering devices at the indoor coil. See the *Lennox XP13 Engineering Handbook* for approved expansion valve kit match-ups. The expansion valve unit can be installed internal or external to the indoor

coil. In applications where an uncased coil is being installed in a field-provided plenum, install the expansion valve in a manner that will provide access for field servicing of the expansion valve. Refer to below illustration for reference during installation of expansion valve unit.

INDOOR EXPANSION VALVE INSTALLATION

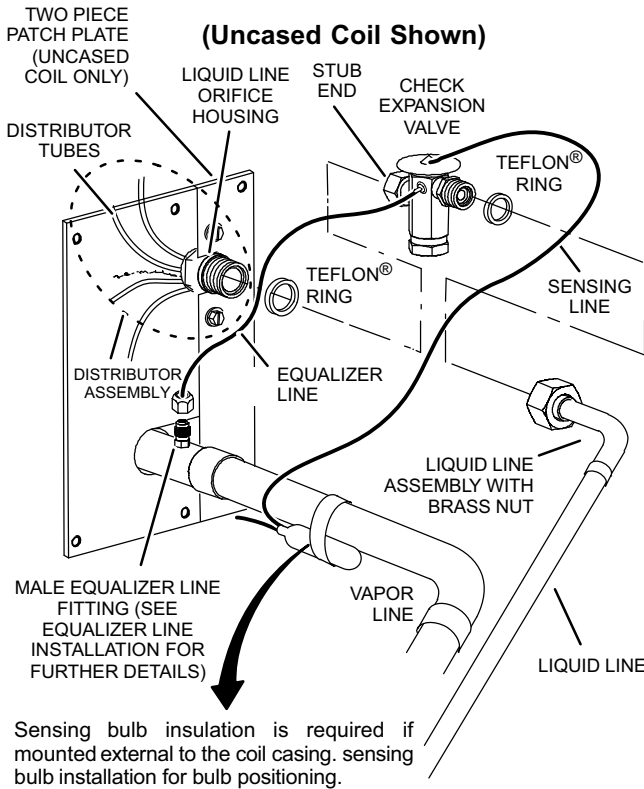

- Remove the field-provided fitting that temporary reconnected the liquid line to the indoor unit's distributor assembly.
- Install one of the provided Teflon® rings around the stubbed end of the expansion valve and lightly lubricate the connector threads and expose surface of the Teflon® ring with refrigerant oil.
- Attach the stubbed end of the expansion valve to the liquid line orifice housing. Finger tighten and use an appropriately sized wrench to turn an additional 1/2 turn clockwise as illustrated in the figure above, or 20 ft-lb.
- Place the remaining Teflon® washer around the other end of the expansion valve. Lightly lubricate connector threads and expose surface of the Teflon® ring with refrigerant oil.
- Attach the liquid line assembly to the expansion valve. Finger tighten and use an appropriately sized wrench to turn an additional 1/2 turn clockwise as illustrated in the figure above or 20 ft-lb.

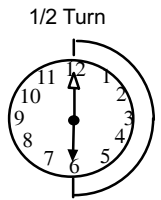

SENSING BULB INSTALLATION

- Attach the vapor line sensing bulb in the proper orientation as illustrated to the right using the clamp and screws provided.

NOTE — Confirm proper thermal contact between vapor line and expansion bulb before insulating the sensing bulb once installed.

- Connect the equalizer line from the expansion valve to the equalizer vapor port on the vapor line. Finger tighten the flare nut plus 1/8 turn (7 ft-lbs) as illustrated below.

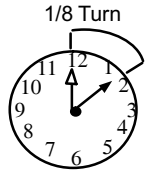

EQUALIZER LINE INSTALLATION

- Remove and discard either the flare seal cap or flare nut with copper flare seal bonnet from the equalizer line port on the vapor line as illustrated in the figure to the right.
- Remove and discard either the flare seal cap or flare nut with copper flare seal bonnet from the equalizer line port on the vapor line as illustrated in the figure to the right.

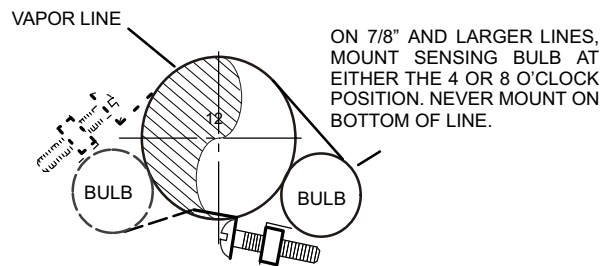
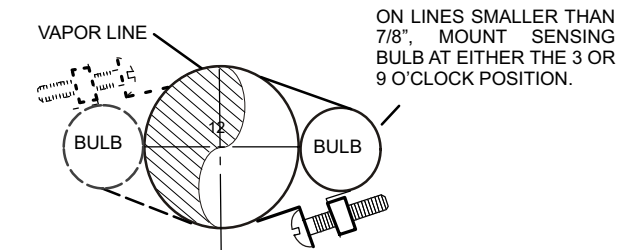
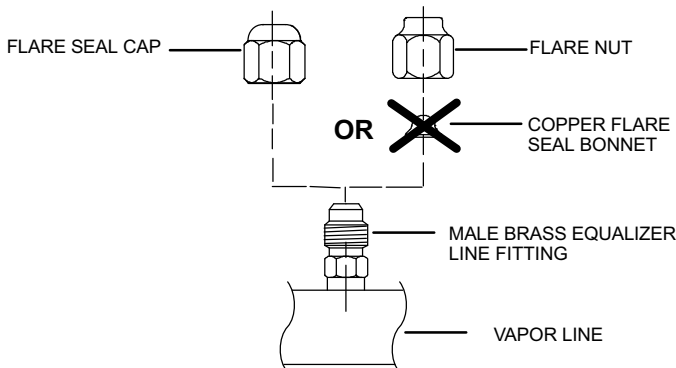

NOTE — NEVER MOUNT ON BOTTOM OF LINE.

Figure 11. Installing Indoor Expansion Valve

⚠ IMPORTANT

The Environmental Protection Agency (EPA) prohibits the intentional venting of HFC refrigerants during maintenance, service, repair and disposal of appliance. Approved methods of recovery, recycling or reclaiming must be followed.

⚠ IMPORTANT

If this unit is being matched with an approved line set or indoor unit coil which was previously charged with mineral oil, or if it is being matched with a coil which was manufactured before January of 1999, the coil and line set must be flushed prior to installation. Take care to empty all existing traps. Polyol ester (POE) oils are used in Lennox units charged with HFC-410A refrigerant. Residual mineral oil can act as an insulator, preventing proper heat transfer. It can also clog the expansion device, and reduce the system performance and capacity. Failure to properly flush the system per the instructions below will void the warranty.

Leak Test Line Set and Indoor Coil

⚠ WARNING



When using a high pressure gas such as dry nitrogen to pressurize a refrigeration or air conditioning system, use a regulator that can control the pressure down to 1 or 2 psig (6.9 to 13.8 kPa).

⚠ IMPORTANT

Leak detector must be capable of sensing HFC refrigerant.

⚠ WARNING

Refrigerant can be harmful if it is inhaled. Refrigerant must be used and recovered responsibly.

Failure to follow this warning may result in personal injury or death.

1 CONNECT GAUGE SET

- A Connect an HFC-410A manifold gauge set high pressure hose to the vapor valve service port.

NOTE — Normally, the high pressure hose is connected to the liquid line port. However, connecting it to the vapor port better protects the manifold gauge set from high pressure damage.

- B With both manifold valves closed, connect the cylinder of HFC-410A refrigerant to the center port of the manifold gauge set.

NOTE — Later in the procedure, the HFC-410A container will be replaced by the nitrogen container.

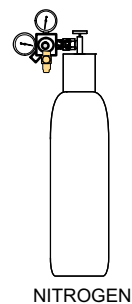

NITROGEN



HFC-410A

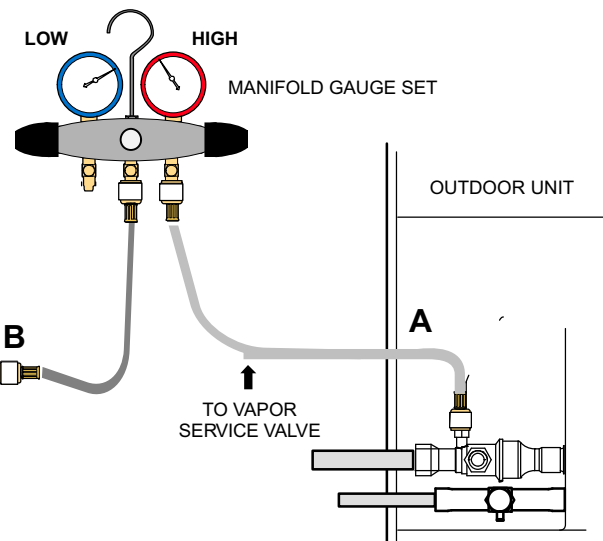

2 TEST FOR LEAKS

After the line set has been connected to the indoor and outdoor units, check the line set connections and indoor unit for leaks. Use the following procedure to test for leaks:

- A With both manifold valves closed, connect the cylinder of HFC-410A refrigerant to the center port of the manifold gauge set. Open the valve on the HFC-410A cylinder (vapor only).
- B Open the high pressure side of the manifold to allow HFC-410A into the line set and indoor unit. Weigh in a trace amount of HFC-410A. [A trace amount is a maximum of two ounces (57 g) refrigerant or three pounds (31 kPa) pressure]. Close the valve on the HFC-410A cylinder and the valve on the high pressure side of the manifold gauge set. Disconnect the HFC-410A cylinder.
- C Connect a cylinder of dry nitrogen with a pressure regulating valve to the center port of the manifold gauge set.
- D Adjust dry nitrogen pressure to 150 psig (1034 kPa). Open the valve on the high side of the manifold gauge set in order to pressurize the line set and the indoor unit.
- E After a few minutes, open one of the service valve ports and verify that the refrigerant added to the system earlier is measurable with a leak detector.
- F After leak testing disconnect gauges from service ports.

Figure 12. Leak Test

Evacuating Line Set and Indoor Coil

1 CONNECT GAUGE SET

NOTE — Remove cores from service valves (if not already done).

- A Connect low side of manifold gauge set with 1/4 SAE in-line tee to vapor line service valve
- B Connect high side of manifold gauge set to liquid line service valve
- C Connect micron gauge available connector on the 1/4 SAE in-line tee.
- D Connect the vacuum pump (with nitrogen gauge) to the center port of the manifold gauge set. The center port line will be used later for both the HFC-410A and nitrogen containers.

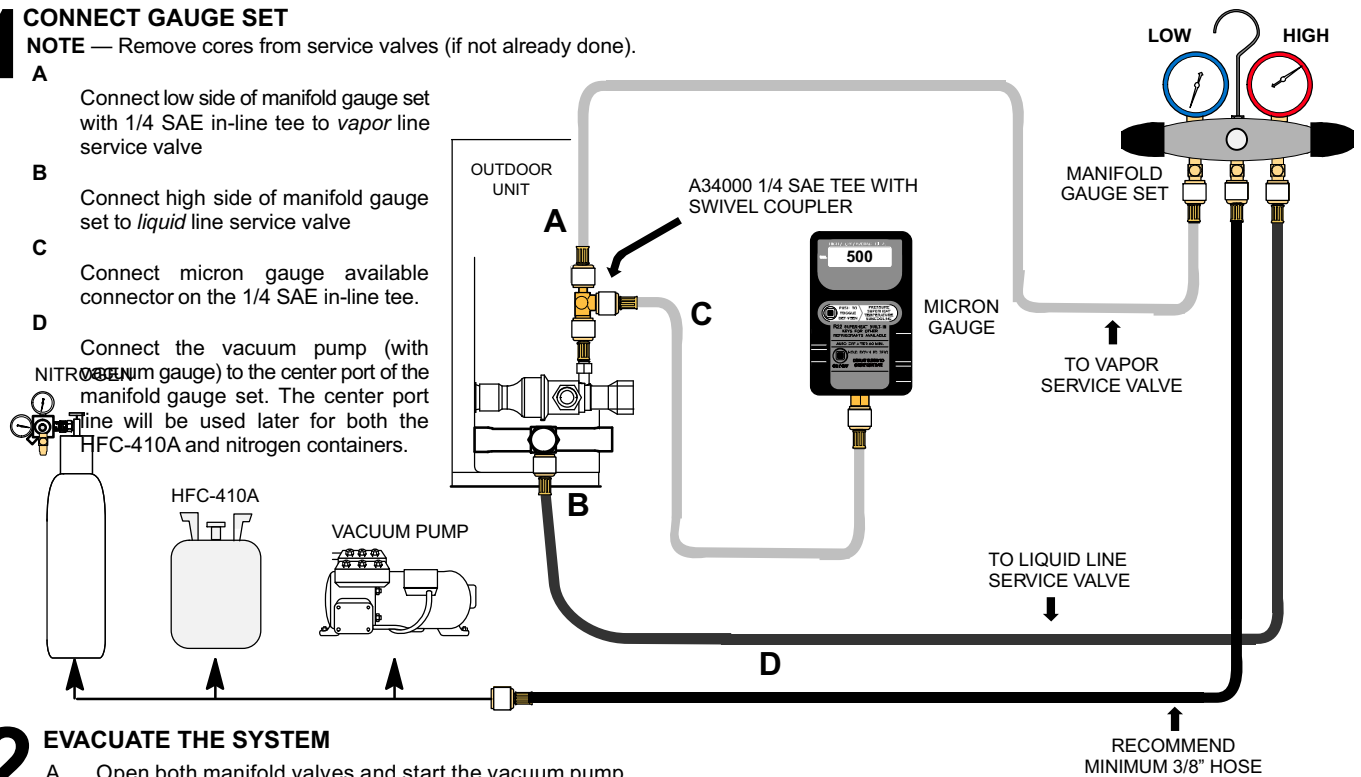

2 EVACUATE THE SYSTEM

- A Open both manifold valves and start the vacuum pump.
- B Evacuate the line set and indoor unit to an **absolute pressure** of 23,000 microns (29.01 inches of mercury).
 - NOTE** — During the early stages of evacuation, it is desirable to close the manifold gauge valve at least once. A rapid rise in pressure indicates a relatively large leak. If this occurs, **repeat the leak testing procedure**.
 - NOTE** — The term **absolute pressure** means the total actual pressure within a given volume or system, above the absolute zero of pressure. Absolute pressure in a vacuum is equal to atmospheric pressure minus vacuum pressure.
- C When the absolute pressure reaches 23,000 microns (29.01 inches of mercury), perform the following:
 - Close manifold gauge valves
 - Close valve on vacuum pump
 - Turn off vacuum pump
 - Disconnect manifold gauge center port hose from vacuum pump
 - Attach manifold center port hose to a dry nitrogen cylinder with pressure regulator set to 150 psig (1034 kPa) and purge the hose.
 - Open manifold gauge valves to break the vacuum in the line set and indoor unit.
 - Close manifold gauge valves.
- D Shut off the dry nitrogen cylinder and remove the manifold gauge hose from the cylinder. Open the manifold gauge valves to release the dry nitrogen from the line set and indoor unit.
- E Reconnect the manifold gauge to the vacuum pump, turn the pump on, and continue to evacuate the line set and indoor unit until the absolute pressure does not rise above 500 microns (29.9 inches of mercury) within a 20-minute period after shutting off the vacuum pump and closing the manifold gauge valves.
- F When the absolute pressure requirement above has been met, disconnect the manifold hose from the vacuum pump and connect it to an upright cylinder of HFC-410A refrigerant. Open the manifold gauge valve 1 to 2 psig in order to release the vacuum in the line set and indoor unit.
- G Perform the following:
 - Close manifold gauge valves.
 - Shut off HFC-410A cylinder.
 - Reinstall service valve cores by removing manifold hose from service valve. Quickly install cores with core tool while maintaining a positive system pressure.
 - Replace stem caps and secure finger tight, then tighten an additional one-sixth (1/6) of a turn as illustrated.

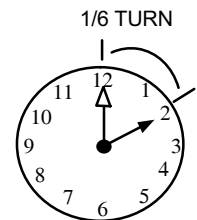

Figure 13. Evacuating System

⚠ IMPORTANT

Use a thermocouple or thermistor electronic vacuum gauge that is calibrated in microns. Use an instrument capable of accurately measuring down to 50 microns.

⚠ WARNING

Danger of Equipment Damage. Avoid deep vacuum operation. Do not use compressors to evacuate a system. Extremely low vacuums can cause internal arcing and compressor failure. Damage caused by deep vacuum operation will void warranty.

Evacuating the system of non-condensables is critical for proper operation of the unit. Non-condensables are defined as any gas that will not condense under

temperatures and pressures present during operation of an air conditioning system. Non-condensables and water suction combine with refrigerant to produce substances that corrode copper piping and compressor parts.

Electrical

In the U.S.A., wiring must conform with current local codes and the current National Electric Code (NEC). In Canada, wiring must conform with current local codes and the current Canadian Electrical Code (CEC).

Refer to the furnace or air handler installation instructions for additional wiring application diagrams and refer to unit nameplate for minimum circuit ampacity and maximum overcurrent protection size.

24VAC TRANSFORMER

Use the transformer provided with the furnace or air handler for low-voltage control power (24VAC - 40 VA minimum)

1 SIZE CIRCUIT AND INSTALL DISCONNECT SWITCH

Refer to the unit nameplate for minimum circuit ampacity, and maximum fuse or circuit breaker (HACR per NEC). Install power wiring and properly sized disconnect switch.

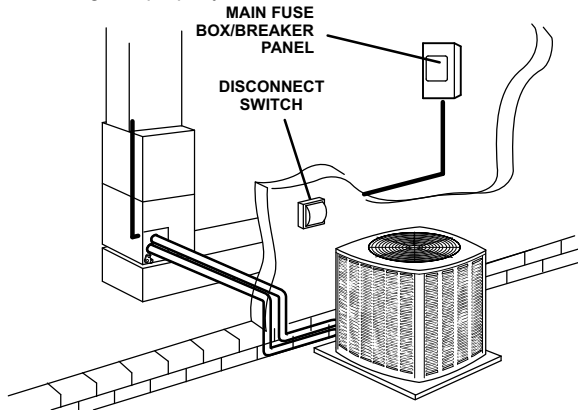

NOTE — Units are approved for use only with copper conductors. Ground unit at disconnect switch or to an earth ground.

2 INSTALL THERMOSTAT

Install room thermostat (ordered separately) on an inside wall approximately in the center of the conditioned area and 5 feet (1.5m) from the floor. It should not be installed on an outside wall or where it can be affected by sunlight or drafts.

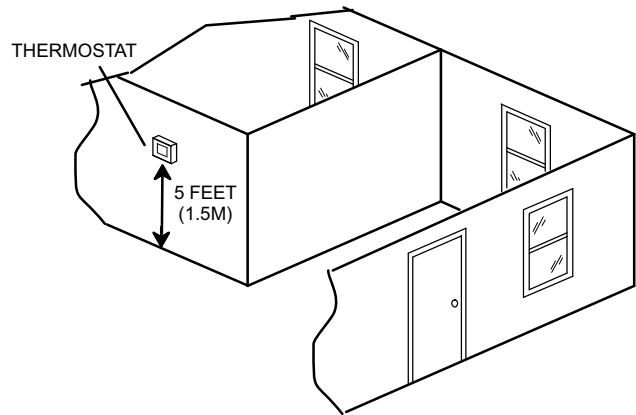

NOTE — 24VAC, Class II circuit connections are made in the control panel.

3 UNIT LOW VOLTAGE CONNECTIONS

- HIGH VOLTAGE FIELD WIRING
- FACTORY WIRING
- LOW VOLTAGE (24V) FIELD WIRING

WIRE RUN LENGTH	AWG#	INSULATION TYPE
LESS THAN 100' (30 METERS)	18	TEMPERATURE RATING
MORE THAN 100' (30 METERS)	16	35°C MINIMUM.

- A** Run 24VAC control wires through cutout with grommet.
- B** Run 24VAC control wires through wire tie.
- C** Make 24VAC control wire connections defrost control terminal strip.
- D** Tighten wire tie to security 24V control wiring.

NOTE - FOR PROPER VOLTAGES, SELECT THERMOSTAT WIRE (CONTROL WIRES) GAUGE PER TABLE ABOVE.

NOTE - WIRE TIE PROVIDES LOW VOLTAGE WIRE STRAIN RELIEF AND TO MAINTAIN SEPARATION OF FIELD INSTALLED LOW AND HIGH VOLTAGE CIRCUITS.

NOTE - DO NOT BUNDLE ANY EXCESS 24VAC CONTROL WIRES INSIDE CONTROL BOX.

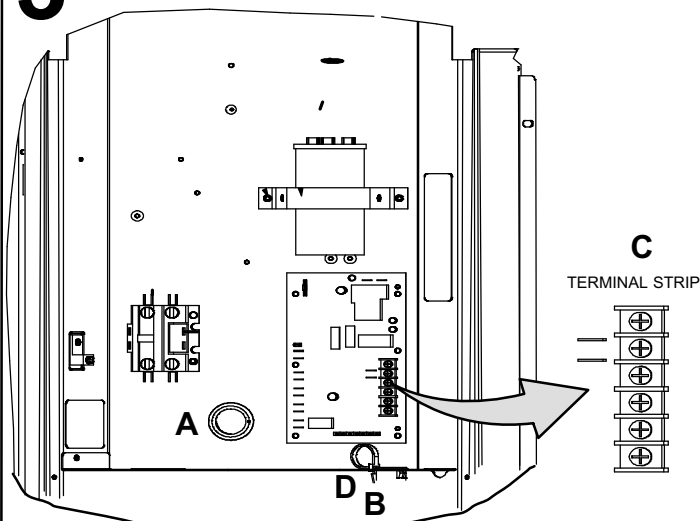

Servicing Units Void of Charge

If the outdoor unit is void of refrigerant, clean the system using the procedure described below.

1. Leak check system using procedure outlined on page 22.
2. Evacuate the system using procedure outlined on page 23.
3. Use nitrogen to break the vacuum and install a new filter drier in the system.
4. Evacuate the system again using procedure outlined on page 23.
5. Weigh in refrigerant using procedure outlined in figure 17.
6. Monitor the system to determine the amount of moisture remaining in the oil. It may be necessary to replace the filter drier several times to achieve the required dryness level. **If system dryness is not verified, the compressor will fail in the future.**

Unit Start-Up

⚠ IMPORTANT

If unit is equipped with a crankcase heater, it should be energized 24 hours before unit start-up to prevent compressor damage as a result of slugging.

1. Rotate fan to check for binding.

2. Inspect all factory- and field-installed wiring for loose connections.
3. After evacuation is complete, open both the liquid and vapor line service valves to release the refrigerant charge contained in outdoor unit into the system.
4. Replace the stem caps and tighten to the value listed in table 1.
5. Check voltage supply at the disconnect switch. The voltage must be within the range listed on the unit's nameplate. If not, do not start the equipment until you have consulted with the power company and the voltage condition has been corrected.
6. Set the thermostat for a cooling demand. Turn on power to the indoor indoor unit and close the outdoor unit disconnect switch to start the unit.
7. Recheck voltage while the unit is running. Power must be within range shown on the nameplate.
8. Check system for sufficient refrigerant by using the procedures listed under *System Charge*.

System Refrigerant

This section outlines procedures for:

1. Connecting gauge set for testing and charging;
2. Checking and adjusting indoor airflow;
3. Adding or removing refrigerant.

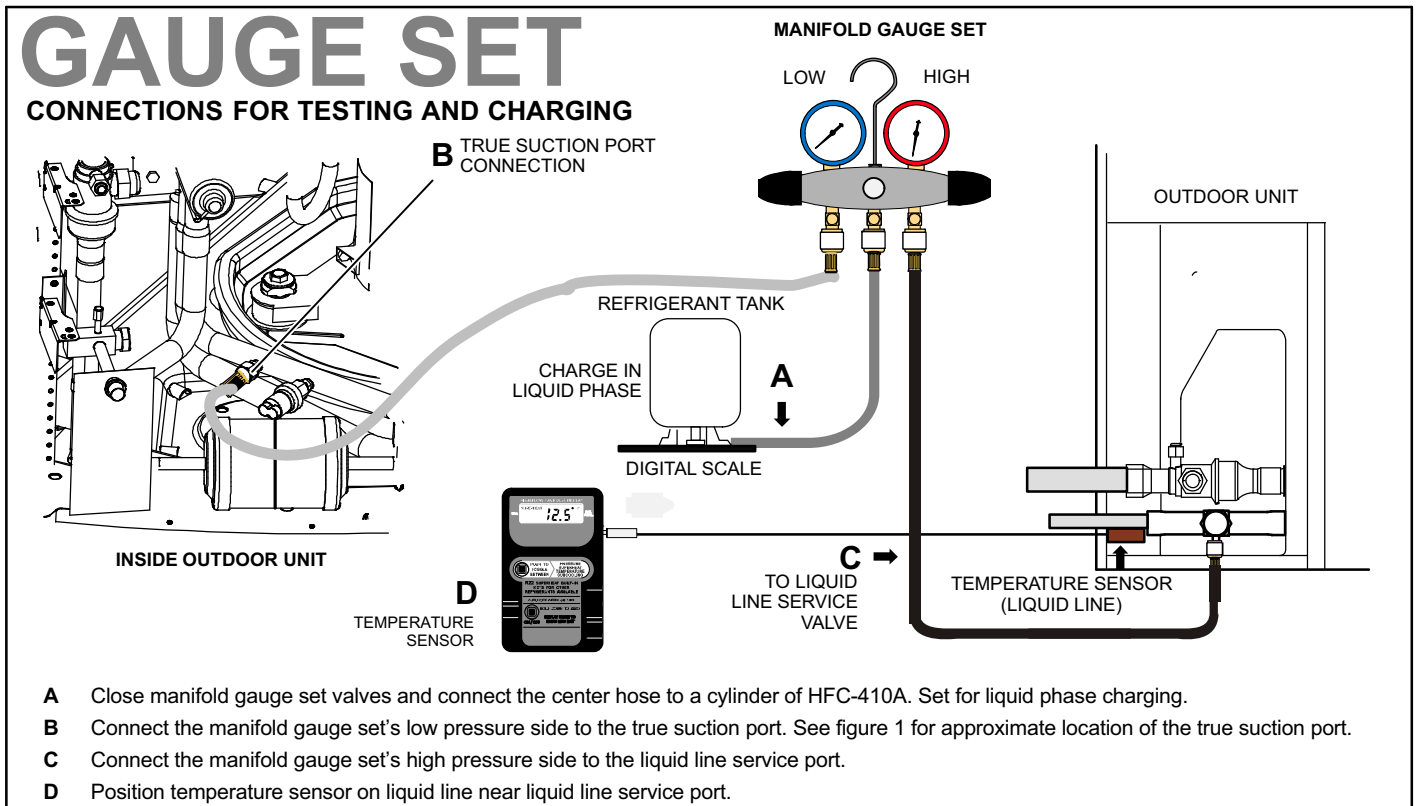

Figure 14. Gauge Set Setup and Connections

CHARGING PROCEDURES FOR XP13-XXX-230-01, XP13-XXX-230-02 AND XP13-037-230-01/-02/-03

The unit is factory-charged with the amount of HFC-410A refrigerant indicated on the unit rating plate. This charge is based on a matching indoor coil and outdoor coil with a 15 foot (4.6 m) line set. This system is charged with HFC-410A refrigerant which operates at much higher pressures than R-22. The recommended check/expansion valve is approved for use with HFC-410A. Do not replace it with a valve designed for use with R-22. This unit is NOT approved for use with coils which include metering orifices or capillary tubes.

PREPARATION

1. Connect the manifold gauge set to the service valves: connect the low pressure gauge to vapor valve service port and the high pressure gauge to liquid valve service port. Connect the center manifold hose to an upright cylinder of HFC-410A. Close manifold gauge set valves.
2. Set the room thermostat to call for heat. This will create the necessary load for properly charging the system in the cooling cycle.
3. Use a digital thermometer to record the outdoor ambient temperature.
4. When the heating demand has been satisfied, switch the thermostat to cooling mode with a set point of 68°F (20°C). When pressures have stabilized, use a digital thermometer to record the liquid line temperature.
5. The outdoor temperature will determine which charging method to use. Proceed with the appropriate charging procedure.

CHARGE USING THE WEIGH-IN METHOD, EXPANSION VALVE (TXV) SYSTEMS—*Outdoor Temperature < 65°F (18°C)*

If the system is void of refrigerant, or if the outdoor ambient temperature is cool, the refrigerant charge should be weighed into the unit. Do this after any leaks have been repaired.

1. Recover the refrigerant from the unit.
2. Conduct a leak check, then evacuate as outlined in the installation instructions.
3. Weigh in the unit nameplate charge.

If weighing facilities are not available or if you are charging the unit during warm weather, follow one of the other procedures outlined below.

CHARGE USING THE SUBCOOLING METHOD—*Outdoor Temperature < 65°F (18°C)*

When the outdoor ambient temperature is below 65°F (18°C), use the subcooling method to charge the unit. It may be necessary to restrict air flow through the outdoor coil to achieve pressures in the 325-375 psig (2240-2585 kPa) range. These higher pressures are necessary for checking the charge. Block equal sections of air intake panels and move obstructions sideways until the liquid pressure is in the 325-375 psig (2240-2585 kPa) range. See figure 15.

Block coil one side at a time with cardboard/plastic until proper testing pressures are reached.

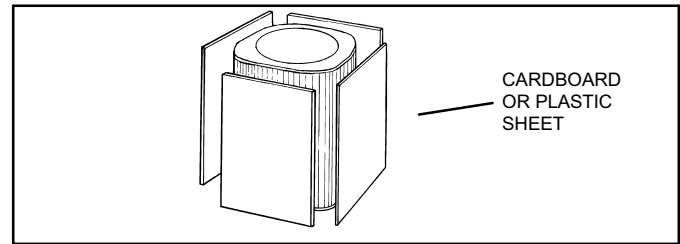

Figure 15. Blocking Outdoor Coil

1. With the manifold gauge hose still on the liquid service port and the unit operating stably, use a digital thermometer to record the liquid line temperature.
2. At the same time, record the liquid line pressure reading.
3. Use a temperature/pressure chart for HFC-410A to determine the saturation temperature for the liquid line pressure reading.
4. Subtract the liquid line temperature from the saturation temperature (according to the chart) to determine subcooling. (**Saturation temperature - Liquid line temperature = Subcooling Value**)
5. Compare the subcooling value with those in table 1. If subcooling is greater than shown, recover some refrigerant. If subcooling is less than shown, add some refrigerant.

CHARGING USING NORMAL OPERATING PRESSURES/APPROACH METHOD—*Outdoor Temperature ≥ 65°F (18°C)*

1. Record outdoor ambient temperature using a digital thermometer.
2. Attach high pressure gauge set and operate unit for several minutes to allow system pressures to stabilize.
3. Compare stabilized pressures with "Normal Operating Pressures" in table 4. Minor variations in these pressures may be expected due to differences in installations. Significant differences could mean that the system is not properly charged or that a problem exists with some component in the system. Pressures higher than those listed indicate that the system is overcharged. Pressures lower than those listed indicate that the system is undercharged. Verify adjusted charge using the approach method.
4. Outdoor temperature should be 65°F (18°C) or above. Use the same digital thermometer used to check outdoor ambient temperature to check liquid line temperature. Verify the unit charge using the approach method. The difference between the ambient and liquid temperatures should match values given in table 2. Loss of charge results in low capacity and efficiency. If the values don't agree with the those in table 2, add refrigerant to lower the approach temperature or recover refrigerant from the system to increase the approach temperature.

USING THE NORMAL OPERATING PRESSURES TABLE

Table 4 may be used to help perform maintenance checks. This table is not a procedure for charging the system and any minor variations in the pressures may be expected due to differences in installations. However, significant deviations could mean that the system is not properly charged or that a problem exists with some component in the system.

Table 3. Approach and Subcooling Values (XP13-XXX-230-01, -02 and XP13-037-230-01, -02, -03)

XP13 Model	-18-01, -02	-24-01	-24-02	-30-01, -02	-36-01, -02	-42-01, -02	-48-01, -02	-60-01, -02
Table 1 - Subcooling Values								
<i>Saturation Temperature minus Liquid Line Temperature °F (°C) ± 1°F (0.5°C)</i>								
Temp. °F (°C)	6 (3.3)	3 (1.7)	3 (1.7)	7 (3.9)	4 (2.2)	5 (2.8)	7 (3.9)	7 (3.9)
Table 2 - Approach Values								
<i>Liquid Line Temperature minus Outdoor Ambient Temperature °F (°C) ± 1°F (0.5°C)</i>								
Temp. °F (°C)	7 (3.9)	11 (6)	11 (6)	11 (6)	15 (8.3)	11 (6)	9(5)	12 (6.7)

Table 3. Normal Operating Pressures - Liquid ±10 and Vapor ±5 PSIG* (XP13-XXX-230-01, -02 and XP13-037-230-01, -02, -03)

XP13 Model	-18-01, -02	-24-01	-24-02	-30-01, -02	-36-01, -02	-42-01, -02	-48-01, -02	-60-01, -02
Table 4 - Normal Operating Pressures (Liquid ±10 & Suction ±5 psig)								
Temp. °F (°C)*	Liquid Line Pressure / Vapor Line Pressure							
Cooling Operation								
65 (18)	228/140	232/139	232/139	245/135	251/134	239/135	244/139	248/129
75 (24)	265/142	268/142	268/142	284/137	292/138	277/136	283/141	289/131
85 (29)	311/144	317/144	317/144	328/140	339/140	321/139	318/143	336/132
95 (35)	350/147	366/146	366/146	377/144	392/143	379/142	369/145	385/133
105 (41)	402/149	412/148	412/148	429/145	443/145	423/144	420/148	440/136
115 (45)	458/152	464/152	464/152	486/147	508/149	484/147	484/150	500/140
Heating Operation								
20 (-7)	278/67	267/55	267/55	278/55	285/57	309/60	277/59	305/59
30 (-1)	294/81	283/72	283/72	294/72	295/77	325/74	291/73	317/72
40 (4.5)	310/96	299/89	299/89	307/88	304/96	336/89	294/92	328/85
50 (10)	328/116	315/109	315/109	324/107	331/106	355/107	323/106	348/105
60 (16)	350/135	331/130	331/130	341/126	361/112	376/118	350/124	370/127
*Air temperature entering outside coil								

08/10



506101-01



CHARGING PROCEDURES FOR XP13-XXX-230-03, -04 AND -05

ADDING OR REMOVING REFRIGERANT

This system uses HFC-410A refrigerant which operates at much higher pressures than HCFC-22. The pre-installed liquid line filter drier is approved for use with HFC-410A only. Do not replace it with components designed for use with HCFC-22. This unit is NOT approved for use with coils which use capillary tubes or fixed orifices as a refrigerant metering device. Check airflow using the Delta-T (DT) process using the illustration in figure 16.

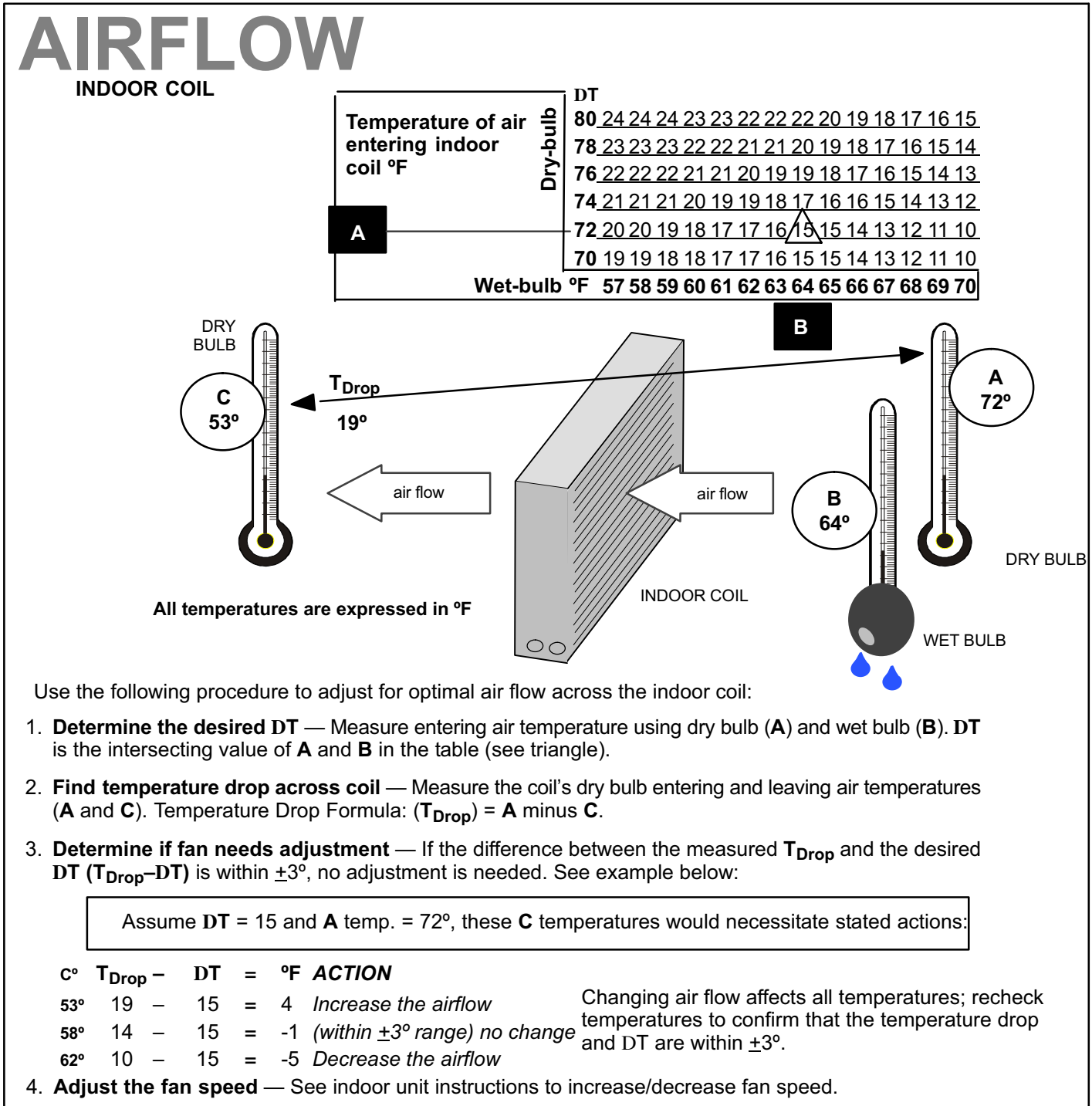

Figure 16. Checking Indoor Airflow over Evaporator Coil using Delta-T Chart

WEIGH IN CHARGING METHOD

CALCULATING SYSTEM CHARGE FOR OUTDOOR UNIT VOID OF CHARGE

If the system is void of refrigerant, first, locate and repair any leaks and then weigh in the refrigerant charge into the unit. To calculate the total refrigerant charge:

$$\begin{array}{ccccccc} \text{Amount specified on} & & \text{Adjust amount, for variation in line set} & & \text{Additional charge specified per indoor} & & \text{Total Charge} \\ \text{nameplate} & & \text{length listed on line set length table below.} & & \text{unit match-ups starting on pages 29} & & \\ & & & & \text{and 30.} & & \\ \hline & & + & & + & & = \end{array}$$



Refrigerant Charge per Line Set Length

LIQUID LINE SET DIAMETER	OUNCES PER 5 FEET (G PER 1.5 M) ADJUST FROM 15 FEET (4.6 M) LINE SET*
3/8" (9.5 MM)	3 OUNCE PER 5' (85 G PER 1.5 M)

*If line length is greater than 15 ft. (4.6 m), add this amount. If line length is less than 15 ft. (4.6 m), subtract this amount.

NOTE — Insulate liquid line when it is routed through areas where the surrounding ambient temperature could become higher than the temperature of the liquid line or when pressure drop is equal to or greater than 20 psig.

NOTE — The above nameplate is for illustration purposes only. Go to actual nameplate on outdoor unit for charge information.

Figure 17. Using HFC-410A Weigh In Method

SUBCOOLING

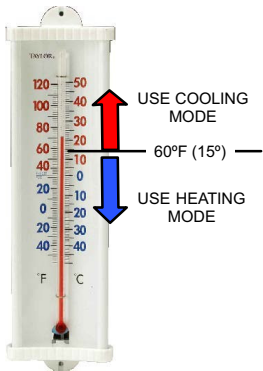

SAT° = _____
 LIQ° = _____
 SC° = _____

- 1 Check the airflow as illustrated in figure 16 to be sure the indoor airflow is as required. (Make any air flow adjustments before continuing with the following procedure.)
- 2 Measure outdoor ambient temperature; determine whether to use **cooling mode** or **heating mode** to check charge.
- 3 Connect gauge set.
- 4 Check Liquid and Vapor line pressures. Compare pressures with Normal Operating Pressures tables. (*The reference tables are a general guide. Expect minor pressure variations. Significant differences may mean improper charge or other system problem.*)
- 5 Set thermostat for heat/cool demand, depending on mode being used:

Using cooling mode—When the outdoor ambient temperature is 60°F (15°C) and above. Target subcooling values in table below are based on 70 to 80°F (21-27°C) indoor return air temperature; if necessary, operate heating to reach that temperature range; then set thermostat to cooling mode setpoint to 68°F (20°C). When pressures have stabilized, continue with step 6.

Using heating mode—When the outdoor ambient temperature is below 60°F (15°C). Target subcooling values in table below are based on 65-75°F (18-24°C) indoor return air temperature; if necessary, operate cooling to reach that temperature range; then set thermostat to heating mode setpoint to 77°F (25°C). When pressures have stabilized, continue with step 6.

- 6 Read the liquid line temperature; record in the LIQ° space.
- 7 Read the liquid line pressure; then find its corresponding temperature in the temperature/ pressure chart listed in table 9 and record it in the SAT° space.
- 8 Subtract LIQ° temp. from SAT° temp. to determine subcooling; record it in SC° space.
- 9 Compare SC° results with match-up tables being sure to note any additional charge for line set and/or match-up.
- 10 If subcooling value is greater than shown in the match up tables for the applicable unit, remove refrigerant; if less than shown, add refrigerant.
- 11 If refrigerant is added or removed, repeat steps 6 through 10 to verify charge.
- 12 Disconnect gauge set and re-install both the liquid and suction service valve caps.

Figure 18. Using Subcooling Method

Table 5. Unit Indoor Matchups for Subcooling (XP13-XXX-230-03)

-018		lb	oz	-030 (continued)				lb	oz	-042 (Continued)				lb	oz
CBX26UH-018	25	5	1	1	CH33-36A	20	3	0	8	CH33-43B	10	12	4	8	
CBX26UH-024	25	5	0	1	CH33-36C	15	3	0	11	CH33-43C	10	6	1	1	
CBX27UH-018/024	15	8	0	2	CH33-42B	20	4	0	11	CH33-44	10	6	0	16	
CBX32MV-018/024	30	3	0	0	CR33-30, -36	15	4	0	11	CH33-48	10	6	1	1	
CBX32MV-024/030	15	8	1	2	CX34-25	15	3	0	12	CH33-49C	10	12	3	12	
-024		lb	oz	-036				lb	oz	-048				lb	oz
CBX26UH-024	26	5	0	1	CX34-31	15	4	0	11	CR33-48	32	5	0	5	
CBX26UH-030	26	3	1	3	CX34-36	27	2	0	0	CR33-50/60	32	9	2	6	
CBX27UH-018/024	12	3	0	11	CX34-38 SN# 6007K and after	4	4	0	11	CX34-43	10	6	1	1	
CBX27UH-030	12	3	1	4	CX34-38 before SN# 6007K	20	4	0	11	CX34-49	10	12	3	7	
CBX32M-030	12	3	0	11	CX34-42	27	2	0	0	CX34-50/60	10	6	1	1	
CBX32M-036	12	3	1	4	CBX26UH-036	25	5	2	2	CX34-60	10	9	2	6	
CBX32MV-018/024	12	6	0	5	CBX27UH-036	10	5	2	2	CBX26UH-048	10	11	0	8	
CBX32MV-024/030	12	3	0	11	CBX27UH-042	10	10	2	8	CBX26UH-060	5	12	3	8	
CH33-25A	16	6	0	7	CBX32M-036, -042	10	5	2	2	CBX27UH-048	10	9	0	7	
CH33-31A	12	3	0	7	CBX32MV-036	10	5	2	2	CBX27UH-060	10	9	0	7	
CH33-31B	12	3	0	15	CH33-31A	10	5	0	2	CBX32M-048	10	9	0	7	
CH33-36A	16	6	0	7	CH33-31B	10	5	1	0	CBX32MV-048	10	9	0	7	
CH33-36B	16	7	0	15	CH33-36C	10	4	0	0	C33-43	0	4	0	3	
CH33-36C	12	5	0	0	CH33-42	10	11	2	3	CH33-43C	13	4	0	3	
CR33-30, -36	12	4	0	3	CH33-44, -48	10	11	2	5	CH33-49C	10	9	0	7	
CX34-25	12	6	0	5	CR33-36	10	4	0	1	CH33-60	10	7	0	5	
CX34-31	12	3	0	11	CR33-48	30	5	2	3	CR33-48	36	4	0	0	
CX34-36	16	7	0	11	CR33-50/60	30	11	2	5	CR33-50/60, -60	35	7	0	5	
-030		lb	oz	-042				lb	oz	-060				lb	oz
CBX26UH-030, -036	25	4	0	11	CX34-38 SN# 6007K and after	5	5	2	2	CX34-60	10	7	0	5	
CBX27UH-030	15	4	0	11	CX34-38 before SN# 6007K	10	5	2	2	CBX26UH-060	10	9	3	3	
CBX27UH-036	15	4	0	11	CX34-44/48	10	5	2	2	CBX27UH-060	10	8	1	12	
CBX32M-030, -036	15	4	0	11	CH23-65	32	6	0	12	CBX32MV-060	10	8	1	12	
CBX32M-042	15	4	0	11	CBX26UH-042	32	6	1	2	CBX32MV-068	10	9	2	5	
CBX32MV-024/030, -036	15	4	0	11	CBX26UH-048	10	12	5	5	CH33-62	10	9	2	7	
CH33-25A	20	3	0	8	CBX27UH-042	15	5	0	0	CR33-60	35	4	0	0	
CH33-31A	15	4	0	11	CBX27UH-048	15	5	0	0	CX34-60	15	4	0	0	
CH33-31B	20	4	0	11	CBX32M-036, -042	15	5	0	0	CX34-62	10	9	2	1	
					CBX32MV-036	15	5	0	0						

**Amount of charge required in addition to charge shown on unit nameplate. (Remember to consider line set length difference.)

Table 6. Normal Operating Pressures - Liquid ± 10 and Vapor ± 5 PSIG* (XP13-XXX-230-03)

Model	-018	-024	-030	-036	-042	-048	-060
°F (°C)*	Liquid Line Pressure/Vapor Line Pressure						
COOLING							
65 (18)	228/140	232/139	245/135	251/134	239/135	244/139	248/129
75 (24)	265/142	268/142	284/137	292/138	277/136	283/141	289/131
85 (29)	311/144	317/144	328/140	339/140	321/139	318/143	336/132
95 (35)	350/147	366/146	377/144	392/143	379/142	369/145	385/133
105 (41)	402/149	412/148	429/145	443/145	423/144	420/148	440/136
115 (45)	458/152	464/152	486/147	508/149	484/147	484/150	500/140
HEATING							
60 (16)	350/135	331/130	341/126	361/112	376/118	350/124	370/127
50 (10)	328/116	315/109	324/107	331/106	355/107	323/106	348/105
40 (4.5)	310/96	299/89	307/88	304/96	336/89	294/92	328/85
30 (-1)	294/81	283/72	294/72	295/77	325/74	291/73	317/72
20 (-7)	278/67	267/55	278/55	285/57	309/60	277/59	305/59

*Temperature of the air entering the outdoor coil.

Table 7. Unit Indoor Matchups for Subcooling (XP13-XXX-230-04 and -05)

INDOOR MATCHUPS	Target Subcooling		**Add charge		INDOOR MATCHUPS	Target Subcooling		**Add charge		INDOOR MATCHUPS	Target Subcooling		**Add charge	
	Heating (+5°F)	Cooling (+1°F)	lb	oz		Heating (+5°F)	Cooling (+1°F)	lb	oz		Heating (+5°F)	Cooling (+1°F)	lb	oz
XP13-018					XP13-030 (Continued)					XP13-042 (Continued)				
CBX26UH-018	23	5	0	1	CH33-31B	20	4	0	11	CH33-43B	10	12	4	8
CBX26UH-024	23	5	0	1	CH33-36A	20	3	0	8	CH33-43C	10	6	1	1
CBX27UH-018/024	15	8	0	2	CH33-36C	15	3	0	11	CH33-44	10	6	0	16
CBX32MV-018/024	30	3	0	0	CH33-42B	20	4	0	11	CH33-48	10	6	1	1
CBX32MV-024/030	15	8	0	2	CR33-30, -36	38	9	1	9	CH33-49C	10	12	3	12
CBX40UHV-024	30	3	0	0	CX34-25	15	3	0	12	CR33-48	32	5	0	5
CBX40UHV-030	15	8	0	2	CX34-31	15	4	0	11	CR33-50/60	32	9	2	6
XP13-024					CX34-36	27	2	0	0	CX34-43	10	6	1	1
CBX26UH-024	23	5	0	1	CX34-38 SN# 6007K and after	4	4	0	11	CX34-49	10	12	3	7
CBX26UH-030	23	3	1	3	CX34-38 before SN# 6007K	20	4	0	11	CX34-50/60	10	6	1	1
CBX27UH-018/024	12	3	0	11	CX34-42	27	2	0	0	CX34-60	10	9	2	6
CBX27UH-030	12	3	1	4	XP13-036					XP13-048				
CBX32M-030	12	3	0	11	CBX26UH-036	25	5	2	2	CBX26UH-048	12	11	0	8
CBX32M-036	12	3	1	4	CBX27UH-036	10	5	2	2	CBX26UH-060	5	12	3	8
CBX32MV-018/024	12	6	0	5	CBX27UH-042	10	10	2	8	CBX27UH-048	10	9	0	7
CBX32MV-024/030	12	3	0	11	CBX32M-036, -042	10	5	2	2	CBX27UH-060	10	9	0	7
CBX40UHV-024	12	6	0	5	CBX32MV-036	10	5	2	2	CBX32M-048	10	9	0	7
CBX40UHV-030	12	3	0	11	CBX40UHV-036	10	5	2	2	CBX32MV-048	10	9	0	7
CH33-25A	16	6	0	7	CH33-31A	10	5	0	2	CBX40UHV-048	10	9	0	7
CH33-31A	12	3	0	7	CH33-31B	10	5	1	0	C33-43	0	4	0	3
CH33-31B	12	3	0	15	CH33-36C	10	4	0	0	CH33-43C	13	4	0	3
CH33-36A	16	6	0	7	CH33-42	10	11	2	3	CH33-49C	10	9	0	7
CH33-36B	16	7	0	15	CH33-44, -48	10	11	2	5	CH33-60	10	7	0	5
CH33-36C	12	5	0	0	CR33-36	10	4	0	1	CR33-48	36	4	0	0
CR33-30, -36	12	4	0	3	CR33-48	30	5	2	3	CR33-50/60, -60	35	7	0	5
CX34-25	12	6	0	5	CR33-50/60	30	11	2	5	CX34-60	10	7	0	5
CX34-31	12	3	0	11	CX34-38 SN# 6007K and after	5	5	2	2	XP13-060				
CX34-36	16	7	0	11	CX34-38 before SN# 6007K	10	5	2	2	CBX26UH-060	10	9	3	3
XP13-030					CX34-44/48	10	5	2	2	CBX27UH-060	10	8	1	12
CBX26UH-030, -036	22	4	0	11	XP13-042					CBX32MV-060	10	8	1	12
CBX27UH-030	15	4	0	11	CH23-65	32	6	0	12	CBX32MV-068	10	9	2	5
CBX27UH-036	15	4	0	11	CBX26UH-042	26	6	1	2	CBX40UHV-060	10	8	1	12
CBX32M-030, -036	15	4	0	11	CBX26UH-048	10	12	5	5	CH33-62	10	9	2	7
CBX32M-042	15	4	0	11	CBX27UH-042	15	5	0	0	CR33-60	35	4	0	0
CBX32MV-024/030, -036	15	4	0	11	CBX27UH-048	15	5	0	0	CX34-60	15	4	0	0
CBX40UHV-024, -030, -036	15	4	0	11	CBX32M-036, -042	15	5	0	0	CX34-62	10	9	2	1
CH33-25A	20	3	0	8	CBX32MV-036	15	5	0	0	**Amount of charge required in additional to charge shown on unit nameplate. (Remember to consider line set length difference.) SN indicates serial number.				
CH33-31A	15	4	0	11	CBX40UHV-036, -042	15	5	0	0					

Table 8. Normal Operating Pressures - Liquid ±10 and Vapor ±5 PSIG* (XP13-XXX-230-04 and -05)

Model	-018	-024	-030	-036	-042	-048	-060
°F (°C)*	Liquid Line Pressure/Vapor Line Pressure						
COOLING							
65 (18)	228/140	232/139	245/135	251/134	239/135	244/139	248/129
75 (24)	265/142	268/142	284/137	292/138	277/136	283/141	289/131
85 (29)	311/144	317/144	328/140	339/140	321/139	318/143	336/132
95 (35)	350/147	366/146	377/144	392/143	379/142	369/145	385/133
105 (41)	402/149	412/148	429/145	443/145	423/144	420/148	440/136
115 (45)	458/152	464/152	486/147	508/149	484/147	484/150	500/140
HEATING							
60 (16)	350/135	348/130	341/123	350/131	366/129	350/120	379/127
50 (10)	321/116	330/109	324/107	331/111	348/107	333/106	361/109
40 (4.5)	301/96	315/89	307/88	304/96	336/89	294/92	341/89
30 (-1)	294/81	301/77	290/76	295/77	317/70	291/73	323/72
20 (-7)	278/64	286/64	274/62	290/62	295/60	283/59	305/59

*Temperature of the air entering the outdoor coil.

Table 9. HFC-410A Temperature (°F) - Pressure (Psig)

°F	Psig	°F	Psig	°F	Psig	°F	Psig	°F	Psig	°F	Psig	°F	Psig	°F	Psig
32	100.8	48	137.1	63	178.5	79	231.6	94	290.8	110	365.0	125	445.9	141	545.6
33	102.9	49	139.6	64	181.6	80	235.3	95	295.1	111	370.0	126	451.8	142	552.3
34	105.0	50	142.2	65	184.3	81	239.0	96	299.4	112	375.1	127	457.6	143	559.1
35	107.1	51	144.8	66	187.7	82	242.7	97	303.8	113	380.2	128	463.5	144	565.9
36	109.2	52	147.4	67	190.9	83	246.5	98	308.2	114	385.4	129	469.5	145	572.8
37	111.4	53	150.1	68	194.1	84	250.3	99	312.7	115	390.7	130	475.6	146	579.8
38	113.6	54	152.8	69	197.3	85	254.1	100	317.2	116	396.0	131	481.6	147	586.8
39	115.8	55	155.5	70	200.6	86	258.0	101	321.8	117	401.3	132	487.8	148	593.8
40	118.0	56	158.2	71	203.9	87	262.0	102	326.4	118	406.7	133	494.0	149	601.0
41	120.3	57	161.0	72	207.2	88	266.0	103	331.0	119	412.2	134	500.2	150	608.1
42	122.6	58	163.9	73	210.6	89	270.0	104	335.7	120	417.7	135	506.5	151	615.4
43	125.0	59	166.7	74	214.0	90	274.1	105	340.5	121	423.2	136	512.9	152	622.7
44	127.3	60	169.6	75	217.4	91	278.2	106	345.3	122	428.8	137	519.3	153	630.1
45	129.7	61	172.6	76	220.9	92	282.3	107	350.1	123	434.5	138	525.8	154	637.5
46	132.2	62	175.4	77	224.4	93	286.5	108	355.0	124	440.2	139	532.4	155	645.0
47	134.6			78	228.0			109	360.0			140	539.0		

System Operation

The outdoor unit and indoor blower cycle on demand from the room thermostat. When the thermostat blower switch is in the **ON** position, the indoor blower operates continuously.

HIGH PRESSURE SWITCH (S4)

The XP13 is equipped with a auto-reset high pressure switch (single-pole, single-throw) which is located on the liquid line. The switch shuts off the compressor when discharge pressure rises above the factory setting. **High Pressure** (auto reset) - trip at 590 psig, reset at 418 psig.

LOW PRESSURE SWITCH (S87)

The XP13 is equipped with an auto-reset low pressure switch which is located on the vapor line. The switch shuts off the compressor when the vapor pressure falls below the factory setting. **Low Pressure** (auto reset) - trip at 25 psig, reset at 40 psig.

CRANKCASE THERMOSTAT (S40) (-042, -048 AND -060 UNITS ONLY)

Compressor in the XP13-042, -048 and -060 units are equipped with a 70 watt, belly band type crankcase heater. HR1 prevents liquid from accumulating in the compressor. HR1 is controlled by a thermostat located on the liquid line. When liquid line temperature drops below 50° F the thermostat closes energizing HR1. The thermostat will open, de-energizing HR1 once liquid line temperature reaches 70° F .

FILTER DRIER

The unit is equipped with a large-capacity biflow filter drier which keeps the system clean and dry. If replacement is necessary, order another of the same design and capacity. The replacement filter drier must be suitable for use with HFC-410A refrigerant.

Defrost System

The XP13 defrost system includes two components: a defrost thermostat and a defrost control board (figure 19).

DEFROST THERMOSTAT

The defrost thermostat is located on the liquid line between the check/expansion valve and the distributor. When defrost thermostat senses 42°F (5.5°C) or cooler, the thermostat contacts close and send a signal to the defrost control board to start the defrost timing. It also terminates defrost when the liquid line warms up to 70°F (21°C).

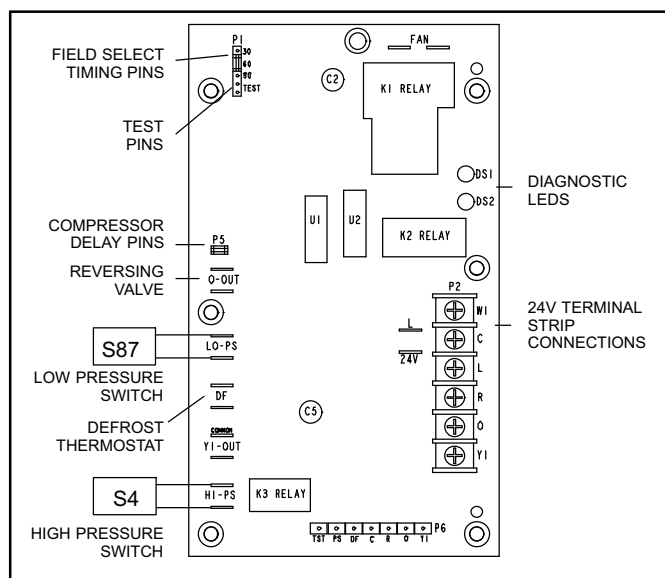

Figure 19. Outdoor Unit Defrost Control Board

DEFROST CONTROL

The defrost control board includes the combined functions of a time/temperature defrost control, defrost relay, diagnostic LEDs and terminal strip for field wiring connections.

TEST

Placing the jumper on the field test pins (E33) allows the technician to:

- Clear short cycle lockout
- Clear five-strike fault lockout
- Cycle the unit in and out of defrost mode
- Place the unit in defrost mode to clear the coil

When Y1 is energized and 24V power is being applied to the control, a test cycle can be initiated by placing a jumper on the control's TEST pins for 2 to 5 seconds. If the jumper remains on the TEST pins for longer than five seconds, the Control will ignore the jumpered TEST pins and revert to normal operation.

The control will initiate one test event each time a jumper is placed on the TEST pins. For each TEST the jumper must be removed for at least one second and then reapplied.

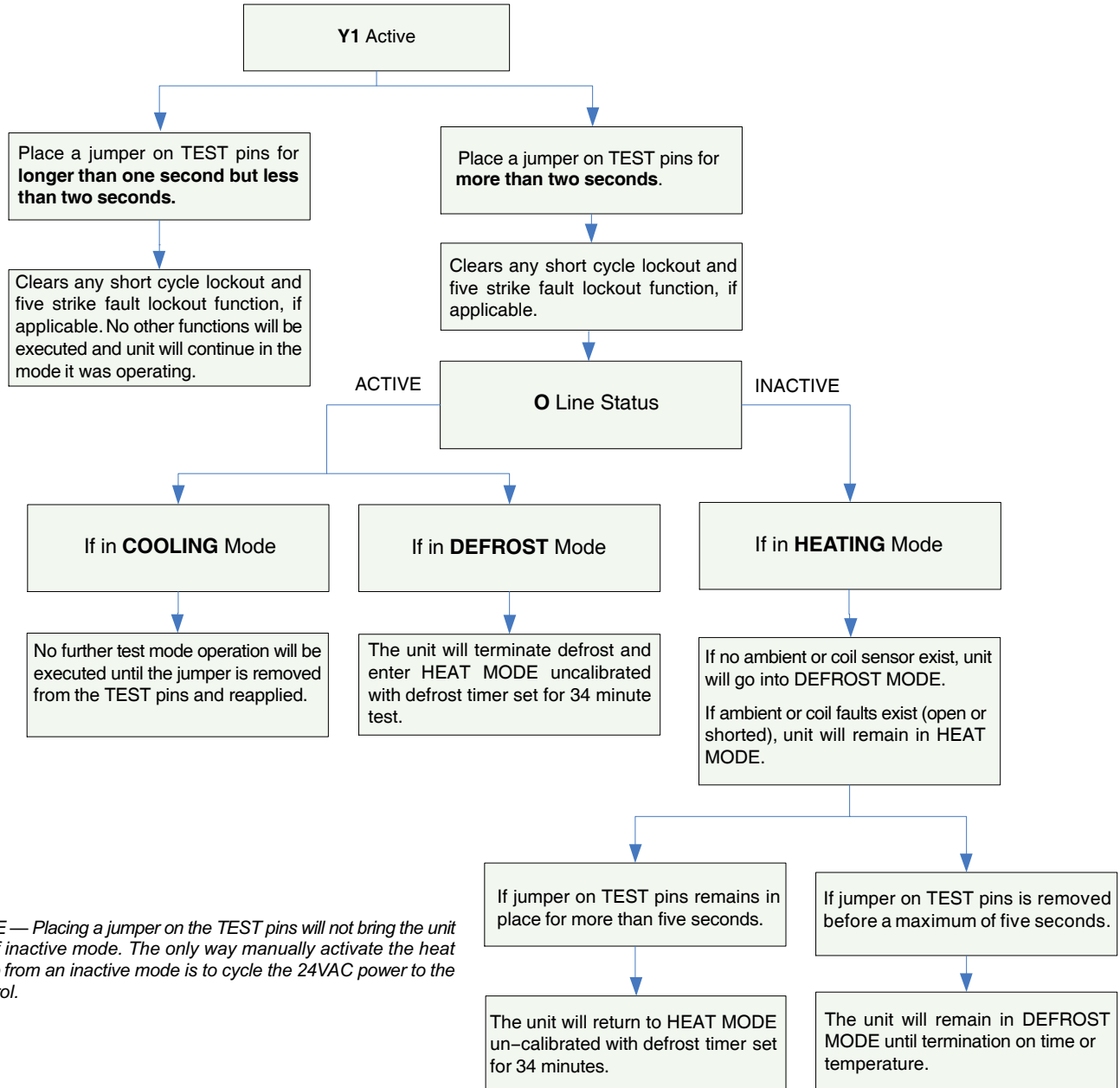
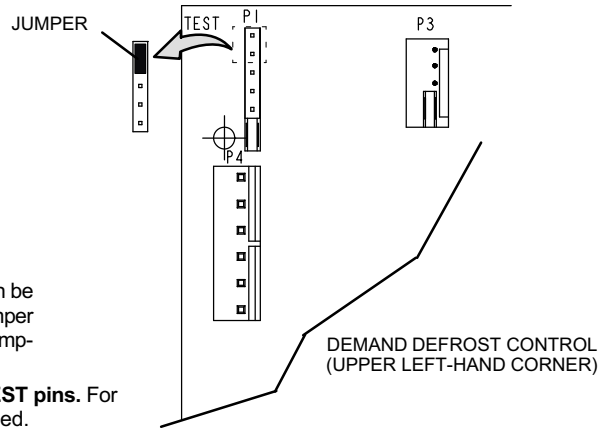

NOTE — Placing a jumper on the TEST pins will not bring the unit out of inactive mode. The only way manually activate the heat pump from an inactive mode is to cycle the 24VAC power to the Control.

Figure 20. Test Mode

The control provides automatic switching from normal heating operation to defrost mode and back. During compressor cycle (call for defrost), the control accumulates compressor run times at 30-, 60-, or 90-minute field-adjustable intervals. If the defrost thermostat is closed when the selected compressor run time interval ends, the defrost relay is energized and defrost begins.

DEFROST CONTROL TIMING PINS

Each timing pin selection provides a different accumulated compressor run time period for one defrost cycle. This time period must occur before a defrost cycle is initiated. The defrost interval can be adjusted to 30 (T1), 60 (T2), or 90 (T3) minutes (see figure 19). The defrost timing jumper is factory-installed to provide a 60-minute defrost interval. If the timing selector jumper is not in place, the control defaults to a 90-minute defrost interval. The maximum defrost period is 14 minutes and cannot be adjusted.

A TEST option is provided for troubleshooting. **The TEST mode may be started any time the unit is in the heating mode and the defrost thermostat is closed or jumpered.** If the jumper is in the TEST position at power-up, the control will ignore the test pins. When the jumper is placed across the TEST pins for two seconds, the control will enter the defrost mode. If the jumper is removed before an additional 5-second period has elapsed (7 seconds total), the unit will remain in defrost mode until the defrost thermostat opens or 14 minutes have passed. If the jumper is not removed until after the additional 5-second period has elapsed, the defrost will terminate and the test option will not function again until the jumper is removed and re-applied.

COMPRESSOR DELAY

The defrost board has a field-selectable function to reduce occasional sounds that may occur while the unit is cycling in and out of the defrost mode. The compressor will be cycled off for 30 seconds going in and out of the defrost mode when the compressor delay jumper is removed.

NOTE - The 30-second compressor feature is ignored when jumpering the TEST pins.

TIME DELAY

The timed-off delay is five minutes long. The delay helps to protect the compressor from short-cycling in case the power to the unit is interrupted or a pressure switch opens. The delay is bypassed by placing the timer select jumper across the TEST pins for 0.5 seconds.

PRESSURE SWITCH CIRCUIT

The defrost control incorporates two pressure switch circuits. The high pressure switch (S4) is factory-connected to the board's HI PS terminals (see figure 19). The board also includes a low pressure, or loss-of-charge-pressure, switch (S87). Switches are shown in wiring diagrams in figure 21.

During a single demand cycle, the defrost control will lock out the unit after the fifth time that the circuit is interrupted by any pressure switch wired to the control board. In addition, the diagnostic LEDs will indicate a locked-out pressure switch after the fifth occurrence of an open

pressure switch as listed in table 10. The unit will remain locked out until power to the board is interrupted, then re-established or until the jumper is applied to the TEST pins for 0.5 seconds.

Table 10. Defrost Control Board Diagnostic LED

Mode	Green LED (DS2)	Red LED (DS1)
No power to control	OFF	OFF
Normal operation / power to control	Simultaneous Slow FLASH	
Anti-short cycle lockout	Alternating Slow FLASH	
Low pressure switch fault	OFF	Slow FLASH
Low pressure switch lockout	OFF	ON
High pressure switch fault	Slow FLASH	OFF
High pressure switch lockout	ON	OFF

NOTE - The defrost control board ignores input from the low-pressure switch terminals as follows:

- during the TEST mode,
- during the defrost cycle,
- during the 90-second start-up period,
- and for the first 90 seconds each time the reversing valve switches heat/cool modes.

DIAGNOSTIC LEDES

The defrost board uses two LEDs for diagnostics. The LEDs flash a specific sequence according to the condition.

Maintenance

Maintenance and service must be performed by a qualified installer or service agency. At the beginning of each cooling season, the system should be checked as follows:

Outdoor Unit

1. Clean and inspect the outdoor coil. The coil may be flushed with a water hose. Ensure the power is turned off before you clean the coil.
2. Outdoor fan motor is prelubricated and sealed. No further lubrication is needed.
3. Visually inspect connecting lines and coils for evidence of oil leaks.
4. Check wiring for loose connections.
5. Check for correct voltage at the unit (with the unit operating).
6. Check amp-draw outdoor fan motor.

UNIT NAMEPLATE: _____ **ACTUAL:** _____

NOTE - If owner reports insufficient cooling, the unit should be gauged and refrigerant charge checked.

Outdoor Coil

It may be necessary to flush the outdoor coil more frequently if it is exposed to substances which are corrosive or which block airflow across the coil (e.g., pet urine, cottonwood seeds, fertilizers, fluids that may contain high levels of corrosive chemicals such as salts)

- Outdoor Coil — The outdoor coil may be flushed with a water hose.
- Outdoor Coil (Sea Coast) — Moist air in ocean locations can carry salt, which is corrosive to most metal. Units that are located near the ocean require frequent inspections and maintenance. These inspections will determine the necessary need to wash the unit including the outdoor coil. Consult your installing contractor for proper intervals/procedures for your geographic area or service contract.

Refer to the unit information service manual for pressure drop tables and procedure.

3. Check blower drive belt for wear and proper tension.
4. Check all wiring for loose connections
5. Check for correct voltage at unit (blower operating).
6. Check amp-draw on blower motor.

UNIT NAMEPLATE: _____ **ACTUAL:** _____

INDOOR UNIT

1. Clean or change filters.
2. Adjust blower speed for cooling. Measure the pressure drop over the coil to determine the correct blower CFM.

INDOOR COIL

1. Clean coil, if necessary.
2. Check connecting lines and coils for signs of oil leaks.
3. Check condensate line and clean, if necessary.

NOTE — The filter and all access panels must be in place any time the unit is in operation.

Start-Up and Performance Checklist		
Job Name _____	Job no. _____	Date _____
Job Location _____	City _____	State _____
Installer _____	City _____	State _____
Unit Model No. _____	Serial No. _____	Service Technician _____
Nameplate Voltage _____		
Rated Load Ampacity _____ Compressor Amperage: _____		
Maximum Fuse or Circuit Breaker _____		
Electrical Connections Tight? <input type="checkbox"/>	Indoor Filter clean? <input type="checkbox"/>	Supply Voltage (Unit Off) _____
Indoor Blower RPM _____	S.P. Drop Over Indoor (Dry) _____	Outdoor Coil Entering Air Temp. _____
Vapor Pressure; _____		
Refrigerant Lines: - Leak Checked? <input type="checkbox"/>	Properly Insulated? <input type="checkbox"/>	Outdoor Fan Checked? <input type="checkbox"/>
Service Valves: --- Fully Opened? <input type="checkbox"/>	Caps Tight? <input type="checkbox"/>	Voltage With Compressor Operating _____
SEQUENCE OF OPERATION		THERMOSTAT
Heating Correct? <input type="checkbox"/>	Cooling Correct? <input type="checkbox"/>	Calibrated? <input type="checkbox"/> Properly Set? <input type="checkbox"/> Level? <input type="checkbox"/>

Unit Wiring Diagram and Sequence of Operations

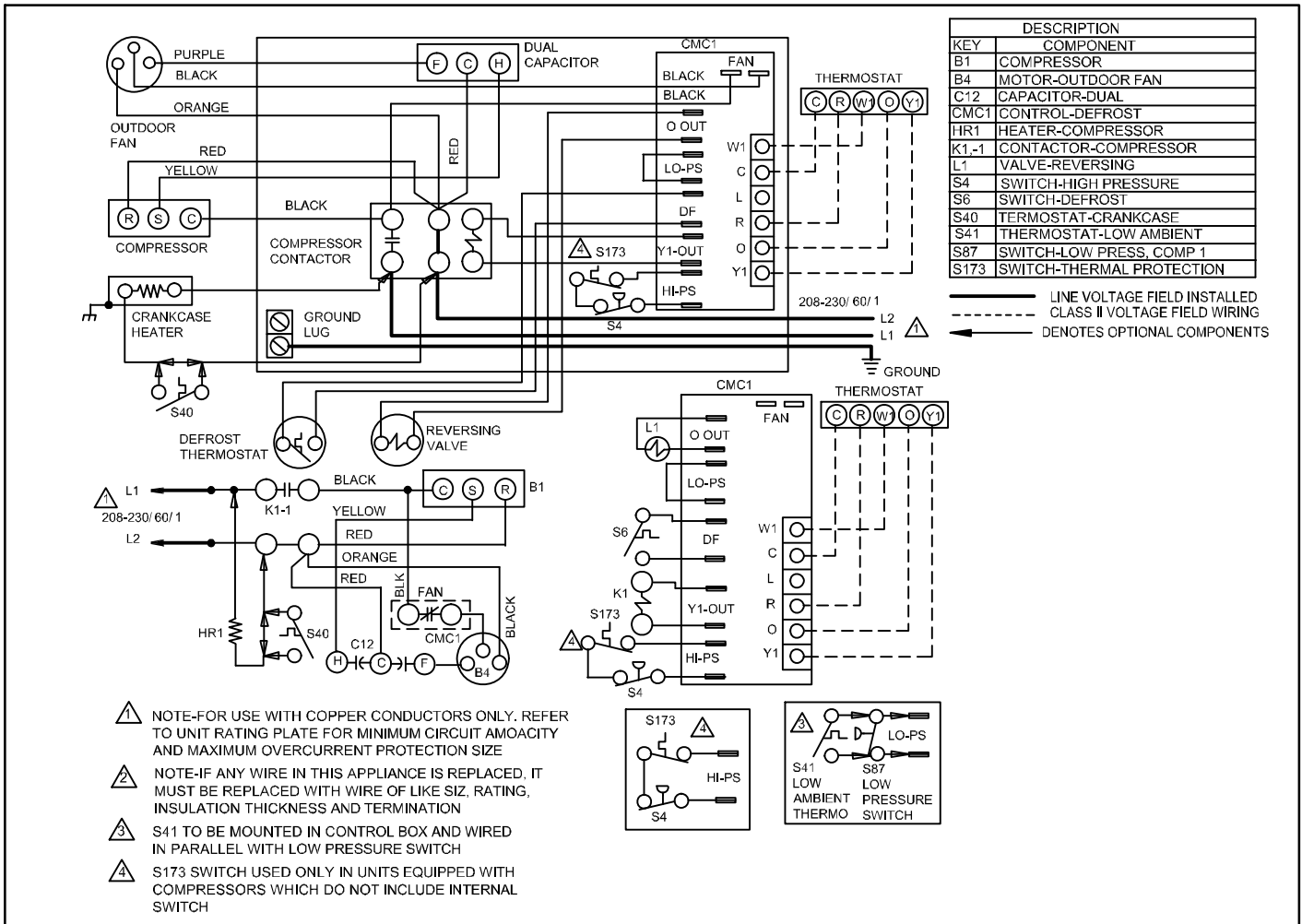

Figure 21. XP13 Unit Wiring Diagram (All Builds)

SEQUENCE OF OPERATIONS

This is the sequence of operation for XP13 series units. The sequence is outlined by numbered steps which correspond to circled numbers on the adjacent diagram.

NOTE- The thermostat used may be electromechanical or electronic.

NOTE- Transformer in indoor unit supplies power (24 VAC) to the thermostat and outdoor unit controls.

COOLING:

Indoor room thermostat wiring energizes terminal O by cooling mode selection, energizing the reversing valve L1. Cooling demand initiates at Y1 in the thermostat.

- 24VAC energizes compressor contactor K1.
- K1-1 N.O. closes, energizing compressor (B1) and outdoor fan motor (B4).

DEFROST MODE:

- When a defrost cycle is initiated, the control energizes the reversing valve solenoid and turns off the condenser fan. The control will also put 24VAC on the "W1" (auxiliary heat) line. The unit will stay in this mode until either the defrost thermostat (S6) temperature is above the termination temperature of 70°, the defrost time of 14 minutes has been completed, or the room

thermostat demand cycle has been satisfied. If the room thermostat demand cycle terminates the cycle, the defrost cycle will be held until the next room thermostat demand cycle. If the defrost thermostat (S6) temperature is still below the termination temperature, the control will continue the defrost cycle until the cycle is terminated in one of the methods mentioned above.

- Compressor (B1) and outdoor fan motor (B4) begin immediate operation.

END OF COOLING DEMAND:

- Cooling demand is satisfied. Terminal Y1 is de-energized.
- Compressor contactor K1 is de-energized.
- K1-1 opens and compressor (B1) and outdoor fan motor (B4) are de-energized and stop immediately.

Terminal O is de-energized when indoor room thermostat is out of cooling mode, de-energizing the reversing valve L1. Heating demand initiates at Y1 in the thermostat.

FIRST STAGE HEATING:

See steps 1, 2 and 3.

END OF HEATING DEMAND:

See steps 4, 5, and 6.