

HP32 SERIES UNITS

The HP32 is a high efficiency residential split-system heat pump unit, which features a scroll compressor and R410A refrigerant. HP32 units are available in sizes ranging from 2 through 5 tons. The series is designed for use with an expansion valve only (approved for use with R410A) in the indoor unit. This manual is divided into sections which discuss the major components, refrigerant system, charging procedure, maintenance and operation sequence. Information contained in this manual is intended for use by qualified service technicians only. All specifications are subject to change.



⚠ IMPORTANT
Operating pressures of this R410A unit are higher than pressures in R22 units. Always use service equipment rated for R410A.

⚠ WARNING
Refrigerant can be harmful if inhaled. Refrigerant must be used and recovered responsibly. Failure to follow this warning can lead to injury or death.

⚠ WARNING
Improper installation, adjustment, alteration, service or maintenance can cause property damage, personal injury or loss of life. Installation and service must be performed by a qualified installer or service agency.

⚠ WARNING
 Electric shock hazard. Can cause injury or death. Before attempting to perform any service or maintenance, turn the electrical power to unit OFF at disconnect switch(es). Unit may have multiple power supplies.

ELECTRICAL DATA

Model No.		HP32-24	HP32-30	HP32-36	HP32-42	HP32-48	HP32-60
Line voltage data - 60 hertz - 1 phase		208/230v					
Rec. max. fuse or circuit breaker size (amps)		30	30	35	40	45	60
*Minimum circuit ampacity		17.7	19.6	20.4	25.2	27.5	36.2
Compressor	Rated load amps	13.5	14.8	15.4	19.3	20.6	27.6
	Power factor	.98		.97	.95	.94	.99
	Locked rotor amps	61.0	72.5	83.0	104.0	109.0	158.0
Outdoor Coil Fan Motor	Full load amps	0.8	1.1			1.7	1.7
	Locked rotor amps	1.6	2.0			3.8	3.8

*Refer to National or Canadian Electrical Code manual to determine wire, fuse and disconnect size requirements.
NOTE — Extremes of operating range are plus 10% and minus 5% of line voltage.

SPECIFICATIONS

Model No.			HP32-24	HP32-30	HP32-36	HP32-42	HP32-48	HP32-60
Nominal Tonnage			2	2.5	3	3.5	4	5
Liquid line conn. o.d. — in. (mm) sweat			3/8 (9.5)					
Vapor line conn. o.d. — in. (mm) sweat			3/4 (19)			7/8 (22.2)		1-1/8 (28.6)
*Refrigerant furnished (R-410A)			7 lbs. 2 oz. (3.23 kg)	10 lbs. 7 oz. (4.73 kg)	9 lbs. 13 oz. (4.45 kg)	9 lbs. 11 oz. (4.39 kg)	12 lbs. 10 oz. (5.75 kg)	14 lbs. 14 oz. (6.75 kg)
Outdoor Coil	Net face area sq. ft. (m ²)	Outer Coil	11.91 (1.11)	16.04 (1.49)		18.33 (1.70)	24.06 (2.24)	
		Inner Coil	8.27 (0.77)	15.56 (1.45)		17.78 (1.65)	23.33 (2.17)	
	Tube diameter — in. (mm)		5/16 (8)					
	No. of rows		2					
	Fins per inch (m)		22 (866)					
Outdoor Coil Fan	Diameter in. (mm) — No. of blades		20 (508) - 4	24 (610) - 3			24 (610) - 4	
	Motor hp (W)		1/10 (75)	1/6 (124)			1/4 (187)	
	Cfm (L/s)		1860 (880)	3000 (1415)		3100 (1465)	4200 (1980)	
	Rpm		825					
	Watts		165	230			345	
Shipping wt. — lbs. (kg) 1 package			193 (88)	198 (90)	243 (110)	252 (114)	265 (120)	362 (164)
OPTIONAL ACCESSORIES - Must Be Ordered Extra								
Mounting Base	Catalog number - Ship. weight		MB2-S (69J06) 6 lbs. (3 kg)	MB2-L (69J07) - 15 lbs. (7 kg)				
	Dimensions - in. (mm)		22-1/4 x 22-1/4 x 3 (565 x 565 x 76)	32 x 34 x 3 (813 x 864 x 76)				
Outdoor Thermostat Kit		Thermostat Kit	LB-29740BA (56A87)					
		Mounting Box	M-1595 (31461) or BM-10260 (33A09) (Canada Only)					

*Refrigerant charge sufficient for 20 ft. (6.1 m) length of refrigerant lines.

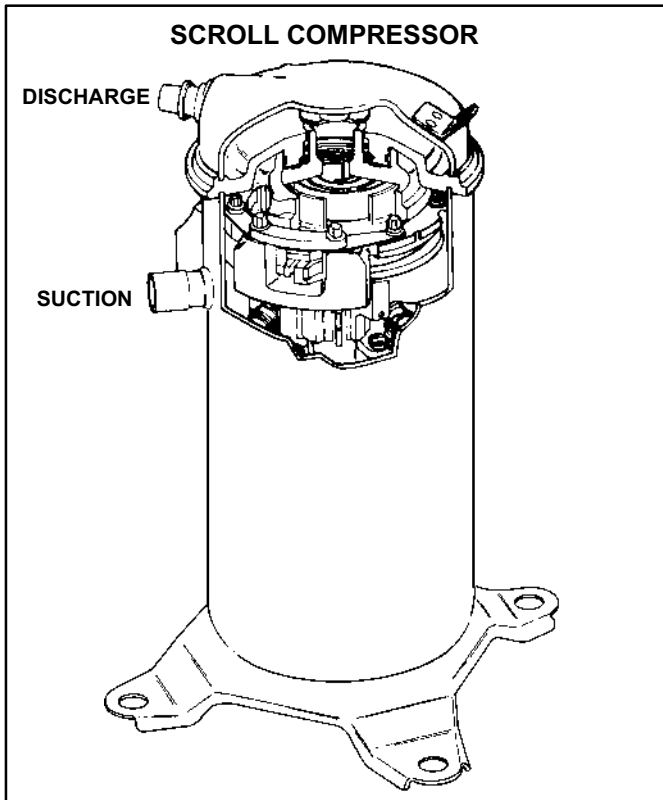

FIGURE 1

I-APPLICATION

All major components (indoor blower and coil) must be matched according to Lennox recommendations for the compressor to be covered under warranty. Refer to the Engineering Handbook for approved system matchups. A misapplied system will cause erratic operation and can result in early compressor failure.

▲ IMPORTANT

This unit must be matched with an indoor coil as specified in Lennox' Engineering Handbook.

II-SCROLL COMPRESSOR

The scroll compressor design is simple, efficient and requires few moving parts. A cutaway diagram of the scroll compressor is shown in figure 1. The scrolls are located in the top of the compressor can and the motor is located just below. The oil level is immediately below the motor.

The scroll is a simple compression concept centered around the unique spiral shape of the scroll and its inherent properties. Figure 2 shows the basic scroll form. Two identical scrolls are mated together forming concentric spiral shapes (figure 3). One scroll remains stationary, while the other is allowed to "orbit" (figure 4). Note that the orbiting scroll does not rotate or turn but merely "orbits" the stationary scroll.

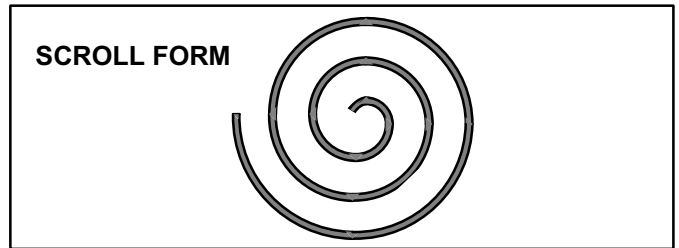

FIGURE 2

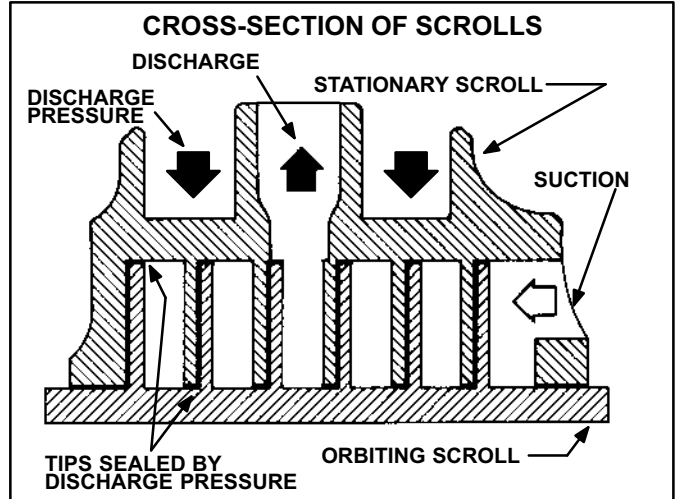

FIGURE 3

The counterclockwise orbiting scroll draws gas into the outer crescent shaped gas pocket created by the two scrolls (figure 4 - 1). The centrifugal action of the orbiting scroll seals off the flanks of the scrolls (figure 4 - 2). As the orbiting motion continues, the gas is forced toward the center of the scroll and the gas pocket becomes compressed (figure 4 -3). When the compressed gas reaches the center, it is discharged vertically into a chamber and discharge port in the top of the compressor (figure 1). The discharge pressure forcing down on the top scroll helps seal off the upper and lower edges (tips) of the scrolls (figure 3). During a single orbit, several pockets of gas are compressed simultaneously providing smooth continuous compression.

The scroll compressor is tolerant to the effects of liquid return. If liquid enters the scrolls, the orbiting scroll is allowed to separate from the stationary scroll. The liquid is worked toward the center of the scroll and is discharged. If the compressor is replaced, conventional Lennox cleanup practices must be used.

Due to its efficiency, the scroll compressor is capable of drawing a much deeper vacuum than reciprocating compressors. Deep vacuum operation can cause internal fuse-site arcing resulting in damaged internal parts and will result in compressor failure. Never use a scroll compressor for evacuating or "pumping-down" the system. This type of damage can be detected and will result in denial of warranty claims.

NOTE - During operation, the head of a scroll compressor may be hot since it is in constant contact with discharge gas.

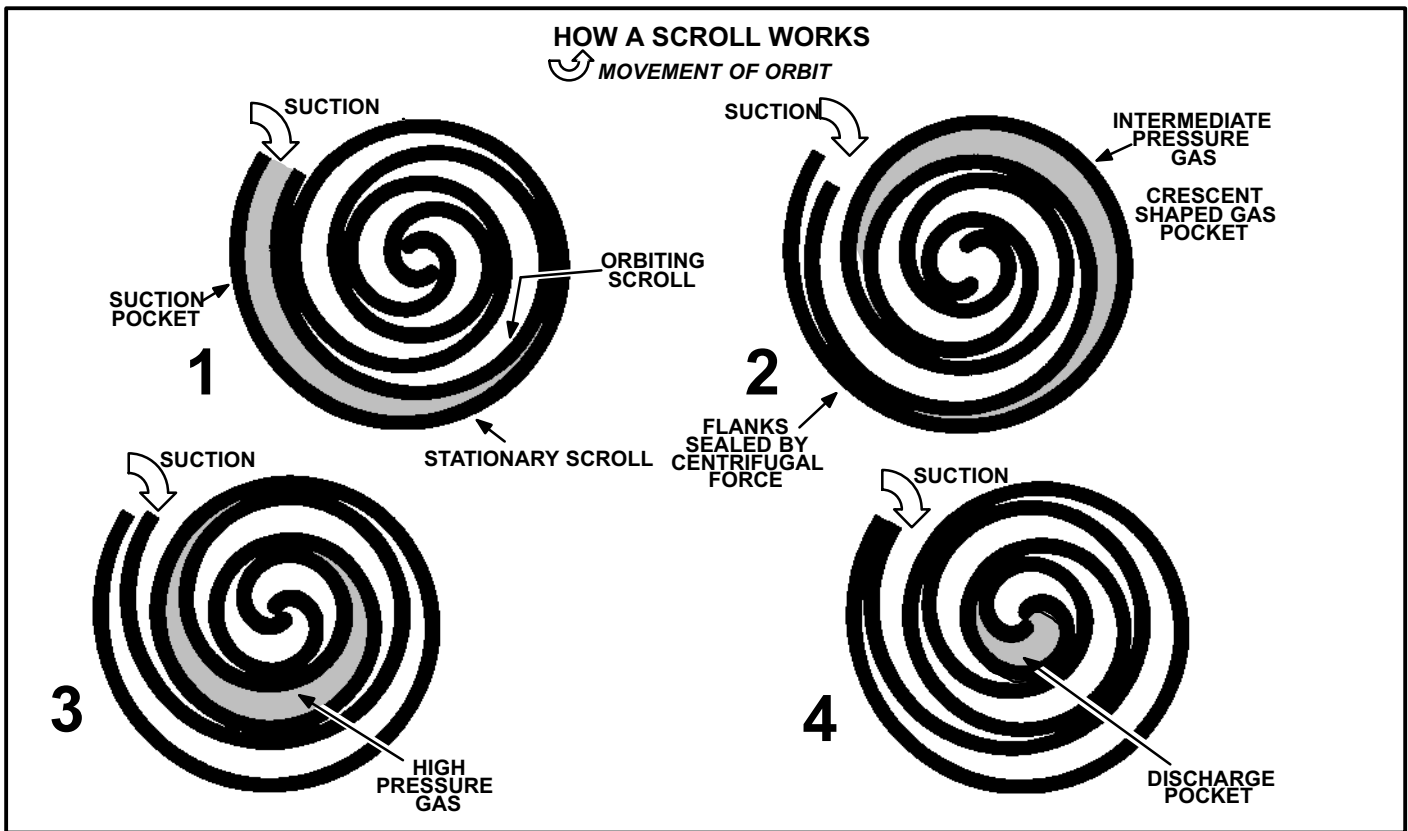

FIGURE 4

C-Drier

All HP32 units are equipped with a filter drier. Driers installed for units using R22 must be replaced. The factory supplied drier is designed to remove moisture, which can lead to compressor failure. **Any time unit is exposed to open air due to service, drier must be replaced. All replacement driers must be approved for R410A refrigerant.**

ELECTROSTATIC DISCHARGE (ESD)

Precautions and Procedures

⚠ CAUTION

Electrostatic discharge can affect electronic components. Take precautions during unit installation and service to protect the unit's electronic controls. Precautions will help to avoid control exposure to electrostatic discharge by putting the unit, the control and the technician at the same electrostatic potential. Neutralize electrostatic charge by touching hand and all tools on an unpainted unit surface before performing any service procedure.

D-Reversing Valve

A refrigerant reversing valve with an electromechanical solenoid is used to reverse refrigerant flow during unit operation. The reversing valve is energized during cooling demand and during defrost. Refer to figures 10 and NO TAG for more information.

III-UNIT COMPONENTS

A-Transformer

The contactor coil, time delay and temperature sensor are all energized by 24VAC supplied by the indoor unit. All other controls in the outdoor unit are powered by line voltage. Refer to unit wiring diagram. The HP32 is not equipped with an internal line voltage to 24V transformer.

B-Contactor

The compressor is energized by a contactor located in the control box. All HP32 -1 and -2 units are single phase and use two-pole contactors. All HP32-3 and later units are single phase but use single-pole contactors.

⚠ DANGER

Electric Shock Hazard.
May cause injury or death.

Disconnect all remote electrical power supplies before opening unit panel. Unit may have multiple power supplies.

Some units are equipped with single-pole contactors. When unit is equipped with a single-pole contactor, line voltage is present at all components (even when unit is not in operation).

E-Compressor

The scroll compressors in all HP32 model units are designed for use with R410A refrigerant and operation at high pressures. Compressors are shipped from the factory with 3MA (32MMA) P.O.E. oil. If oil must be added for service, Copeland has approved Mobil EAL™ Arctic 22CC and ICI EMKARATE™ RL32CF for use with these compressors. Lennox recommends adding 1 oz. of oil per additional 10 ft. for applications with line sets over 50 ft. See electrical section in this manual for compressor specifications.

F-High Pressure Switch

! IMPORTANT

Pressure switch settings for R410A refrigerant will be significantly higher than units with R22.

An auto-reset, single-pole/single-throw high pressure switch is located in the liquid line. This switch shuts off the compressor when liquid line pressure rises above the factory setting. The switch is normally closed and is permanently adjusted to trip (open) at 640 ± 10 psi. See figure 5 for switch location.

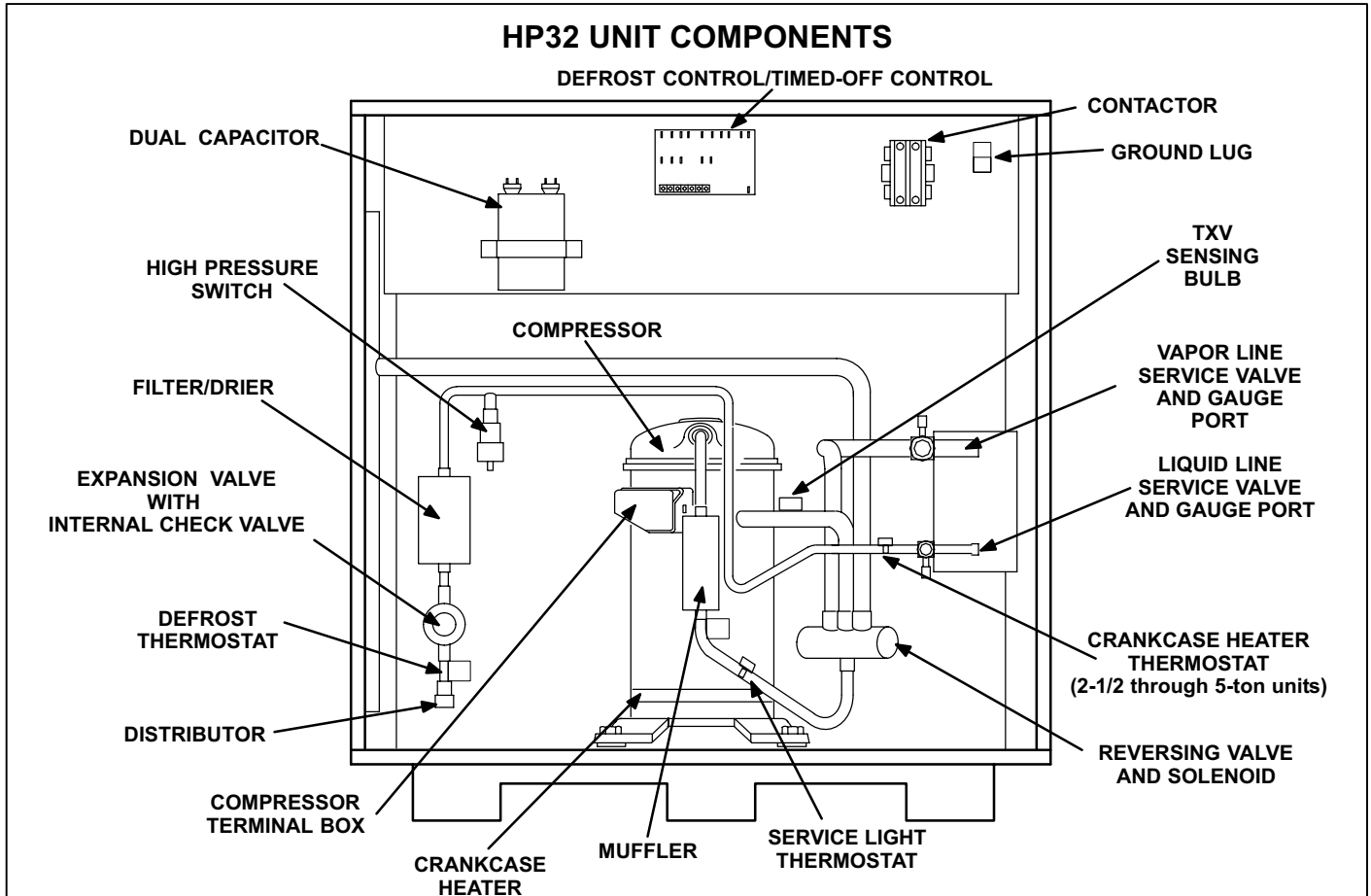

FIGURE 5

Dual Capacitor

The compressor and fan in HP32 single-phase units use permanent split capacitor motors. A single “dual” capacitor is used for both the fan motor and the compressor (see unit wiring diagram). The two sides (fan and compressor) of the capacitor have different mfd ratings and may change with each compressor. The capacitor is located inside the unit control box.

G-Condenser Fan Motor

All units use single-phase PSC fan motors which require a run capacitor. The “FAN” side of the dual capacitor is used for this purpose. In all units, the outdoor fan is controlled by the compressor contactor. See ELECTRICAL DATA and SPECIFICATIONS section for more information. See figure 6 if condenser fan motor replacement is necessary.

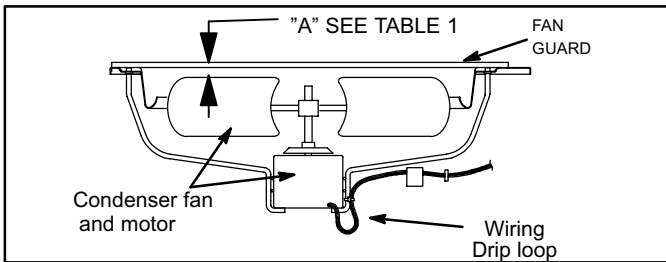

FIGURE 6

TABLE 1

HP32 UNIT	"A" DIM. $\pm 1/8"$	Fan Blade
-24	7/8"	Lau
		Revcor
-30, -36, -42	1-1/16"	Lau
		Revcor
-48	1-3/4"	Lau
	1-1/2"	Revcor
-60	1-3/16"	Lau
		Revcor

H-Service Light Thermostat

All units are equipped with a service light thermostat located on the compressor discharge line. The switch is electrically connected to the service light in the indoor thermostat. The service light, when lit, indicates the compressor is not running. The service light thermostat will close and light when the discharge line falls below $110 \pm 5^\circ\text{F}$, indicating a problem in the system. The service light thermostat opens and the service light goes off when discharge line reaches $130 \pm 5^\circ\text{F}$ indicating the compressor is running. Service light connections are made on terminals on the defrost control board (figure 8).

I-Ambient Compensating Thermistor

All HP32s have an ambient compensating thermistor mounted on the outdoor fan wiring harness. The thermistor is an NTC thermistor (negative temperature coefficient - increase in temperature equals decrease in resistance) (see figure 7). The device is connected in series with the heat anticipation resistor inside the indoor thermostat. The thermistor varies the indoor thermostat heat anticipator current according to outdoor ambient temperature to prevent abnormal thermostat droop. As outdoor temperature increases, the resistance across the thermistor drops. As the resistance across the thermistor drops, the current through the heat anticipation resistor increases. Therefore, heat anticipation increases as outdoor temperature decreases. Resistance at $77^\circ\text{F} = 260 \text{ ohms} \pm 5\%$; at $100^\circ\text{F} = 150 \text{ ohms}$; at $32^\circ\text{F} = 861 \text{ ohms}$. Ambient thermistor connections are made at terminals on the defrost control.

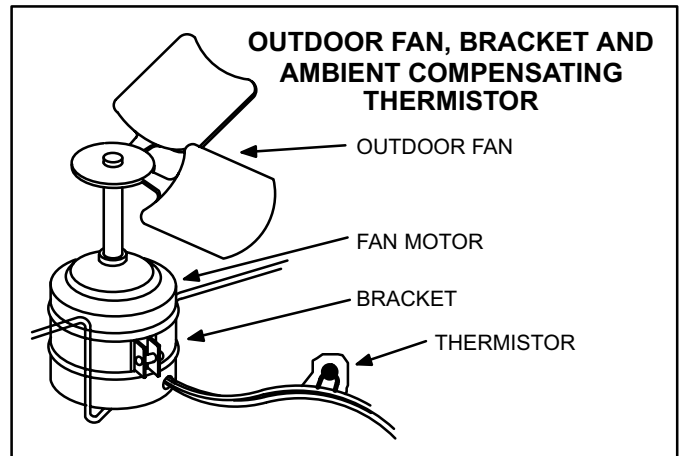

FIGURE 7

J-Defrost System HP32 -1 / -3 Units

The defrost system includes two components: a defrost thermostat, and a defrost control.

Defrost Thermostat

The defrost thermostat is mounted on the liquid line between the check/expansion valve and the distributor. When defrost thermostat senses 35°F (2°C) or cooler, its contacts close and send a signal to the defrost control board to start the defrost timing. It also terminates defrost when the liquid line warms up to 70°F (21°C).

Defrost Control

The defrost control board combines functions of a time/temperature defrost control, defrost relay, time delay, diagnostic LEDs and field connection terminal strip. See figure 8.

The control provides automatic switching from normal heating operation to defrost mode and back. During compressor cycle (room thermostat demand cycle), if the “O” input is not on and the defrost thermostat is closed the control accumulates compressor run times at 30, 60 or 90 minute field adjustable intervals. If the defrost thermostat remains closed when the accumulated compressor run time ends, the defrost relay is energized and defrost begins.

Defrost Control Components

1- Defrost Control Timing Pins

Each timing pin selection provides a different accumulated compressor run period during one thermostat run cycle. This time period must occur before a defrost cycle is initiated. The defrost interval can be adjusted to 30, 60 or 90 minutes. See figure 8. The defrost period is a maximum of 14 minutes and cannot be adjusted. If no timing is selected, the control defaults to 90 minutes.

A TEST option is provided for troubleshooting. When the jumper is placed across the TEST pins, the timing of all functions is reduced by a factor of 128. For example, a 30 minute interval during TEST is 14 seconds and the 14-minute defrost is reduced to 6.5 seconds.

The TEST mode may be started at anytime. If the jumper is in the TEST position at power-up or for longer than five minutes, the control will ignore the TEST selection and will default to a 90 minute interval.

2- Time Delay

The timed-off delay is five minutes long. The delay feature is provided to help protect the compressor in case of an interruption in power to the unit or when a pressure switch resets.

3- Pressure Switch Safety Circuits

The defrost control incorporates a pressure switch safety circuit that allows the application of an additional pressure switch; high pressure switch (S4) is factory-wired to this circuit. See figure 8. PS1 and PS2 terminals are wired in series with a jumper internal to the control board.

During one demand cycle, the defrost control will lock out the unit on the third instance that the unit goes off on any auto-reset pressure switch. The diagnostic LEDs will display a pattern for a locked out pressure switch on the third open pressure switch occurrence. See table 2. The unit will remain locked out until 24 volt power is broken to terminal “R” on the defrost control and then remade. (making and breaking the thermostat **will not** reset the board). Units with board date coded 9936-08: unit will remain locked out until Y1 demand is removed. (making and breaking thermostat **will** reset board)

NOTE- If manual reset high pressure switch is used, unit will not experience 3 pressure trips during one demand cycle and the board will not lockout.

The PS2 safety circuit terminals are connected to the compressor thermostat. An optional switch may be field-installed by connecting it in series with the other switches. See figure 8.

4- Diagnostic LEDs

The defrost board uses two LEDs for diagnostics. The LEDs flash a specific sequence according to the condition.

TABLE 2

DEFROST CONTROL BOARD DIAGNOSTIC LED		
MODE	LED 1	LED 2
Normal Operation/ Power to board	Flash together with LED 2	Flash together with LED 1
Time Delay To Protect Compressor	Alternating Flashes with LED 2	Alternating Flashes with LED 1
Pressure Switch Open	Off	On
Pressure Switch Lockout	On	Off
Board Malfunction	On	On

5- Ambient Thermistor & Service Light Connection

The defrost control board provides terminal connections for the ambient thermistor and service light. These features provide a service light thermostat which activates the room thermostat service light during periods of inefficient operation. The thermistor compensates for changes in ambient temperature which might cause thermostat droop.

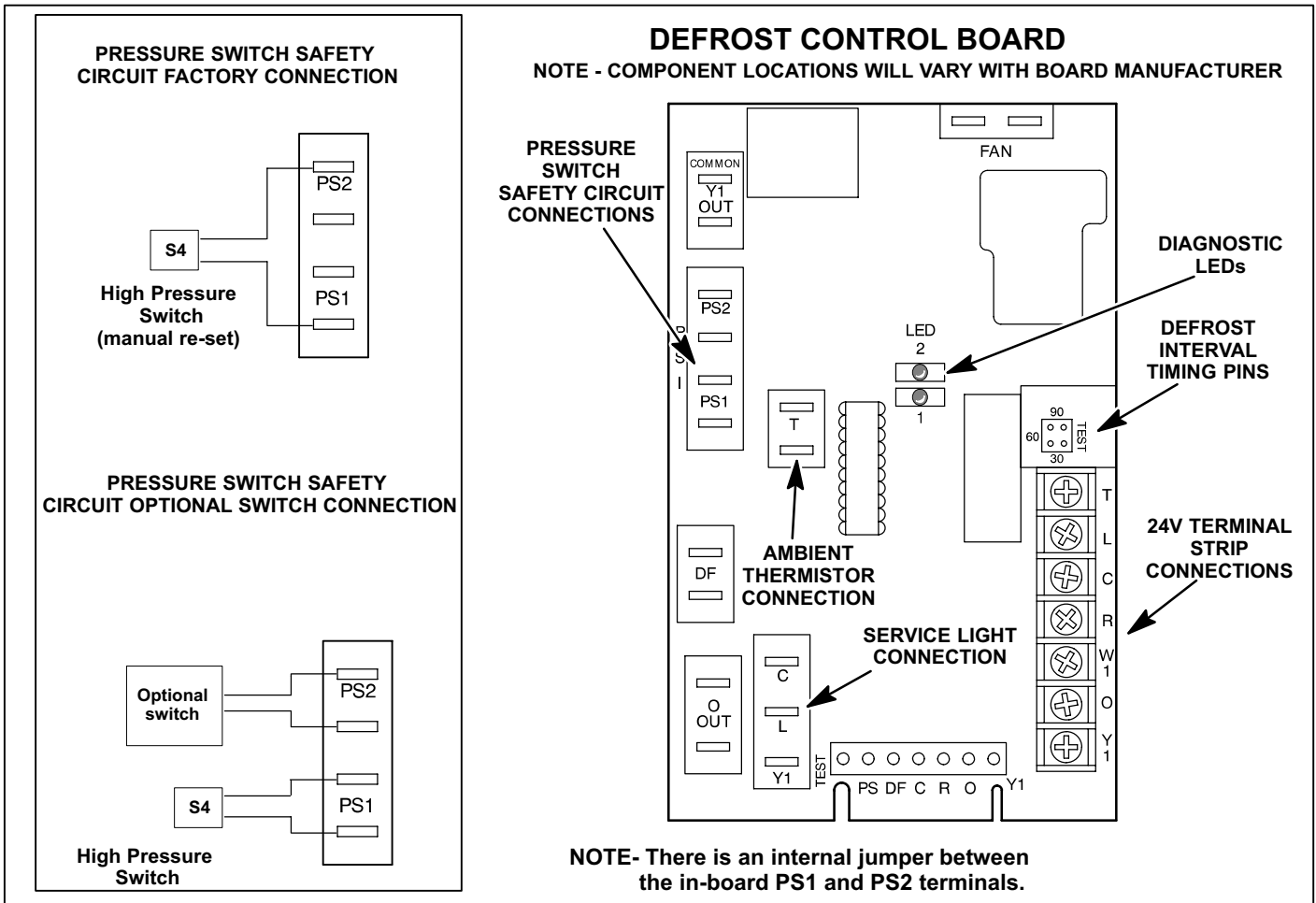

FIGURE 8

K-Defrost System HP32 -4 Units

The defrost system includes two components:

- a defrost thermostat
- a defrost control

Defrost Thermostat

The defrost thermostat is located on the liquid line between the check/expansion valve and the distributor. When the defrost thermostat senses 42°F (5.5°C) or cooler, its contacts close and send a signal to the defrost control board to start the defrost timing. It also terminates defrost when the liquid line warms up to 70°F (21°C).

Defrost Control

The defrost control board includes the combined functions of a time/temperature defrost control, defrost relay, time delay, diagnostic LEDs, and a terminal strip for field wiring connections. See figure 9.

The control provides automatic switching from normal heating operation to defrost mode and back. During compressor cycle (call for defrost), the control accumulates compressor run times at 30, 60, or 90 minute field adjustable intervals. If the defrost thermostat is closed when the selected compressor run time interval ends, the defrost relay is energized and defrost begins.

Defrost Control Timing Pins

Each timing pin selection provides a different accumulated compressor run time period during one thermostat run cycle. This time period must occur before a defrost cycle is initiated. The defrost interval can be adjusted to 30 (T1), 60 (T2), or 90 (T3) minutes. See figure 9. The defrost timing jumper is factory-installed to provide a 90-minute defrost interval. If the timing selector jumper is not in place, the control defaults to a 90-minute defrost interval. The maximum defrost period is 14 minutes and cannot be adjusted.

A TEST option is provided for troubleshooting. **The TEST mode may be started any time the unit is in the heating mode and the defrost thermostat is closed or jumped.** If the jumper is in the TEST position at power-up, the control will ignore the test pins. When the jumper is placed across the TEST pins for two seconds, the control will enter the defrost mode. If the jumper is removed before an additional 5-second period has elapsed (7 seconds total), the unit will remain in defrost mode until the defrost thermostat opens or 14 minutes have passed. If the jumper is not re-

moved until after the additional 5-second period has elapsed, the defrost will terminate and the test option will not function again until the jumper is removed and re-applied.

Time Delay

The timed-off delay is five minutes long. The delay helps protect the compressor from short-cycling in case the power to the unit is interrupted or a pressure switch opens. The delay is bypassed by placing the timer select jumper across the TEST pins for 0.5 seconds.

Pressure Switch Circuits

The defrost control includes two pressure switch circuits. The high pressure switch (S4) is factory-connected to the board's HI PS terminals. The board also includes LO PS terminals to accommodate the addition of a field-provided low pressure or loss of charge pressure switch. See figure 9. This feature is available on all units.

During a single demand cycle, the defrost control will lock out the unit after the third time that the circuit is interrupted by any pressure switch that is wired to the control board. In addition, the diagnostic LEDs will indicate a locked out pressure switch after the third occurrence of an open pressure switch. See table 3. The unit will remain locked out until power is broken then remade to the control or until the jumper is applied to the TEST pins for 0.5 seconds.

NOTE - The defrost control board ignores input from the low pressure switch terminals during the TEST mode, during the defrost cycle, during the 90-second start-up period, and for the first 90 seconds each time the reversing valve

switches heat/cool modes. If the TEST pins are jumpered and the 5-minute delay is being bypassed, the LO PS terminal signal is not ignored during the 90-second start-up period.

Ambient Thermistor & Service Light Connection

The defrost control board provides terminal connections for the ambient thermistor and a service light. The thermistor compensates for changes in ambient temperature which might cause thermostat droop. The service light thermostat provides a signal which activates the room thermostat service light during periods of inefficient operation.

Diagnostic LEDs

The defrost board uses two LEDs for diagnostics. The LEDs flash a specific sequence according to the diagnosis.

TABLE 3

DEFROST CONTROL BOARD DIAGNOSTIC LED		
MODE	LED 1	LED 2
Normal operation / power to board	Synchronized Flash with LED 2	Synchronized Flash with LED 1
Board failure or no power	Off	Off
Board failure	On	On
High pressure switch open	Flash	On
Low pressure switch open	On	Flash
Pressure switch lockout	On	Off
Anti-short-cycle / 5-minute delay	Alternating Flash with LED 2	Alternating Flash with LED 1

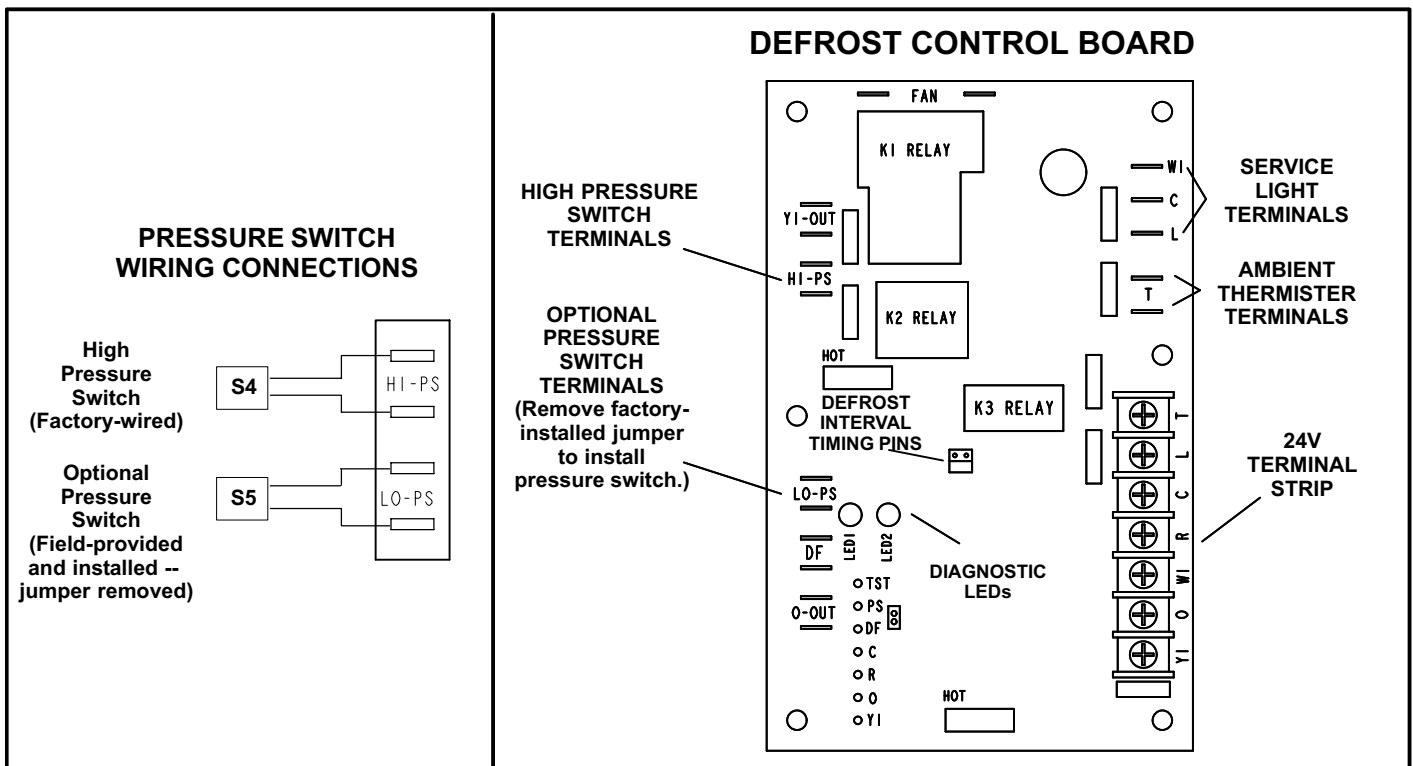

FIGURE 9

IV-REFRIGERANT SYSTEM

Field refrigerant piping consists of liquid and vapor lines from the outdoor unit (sweat connections). Use Lennox L10 or L15 series line sets as shown in table 4 for field-fabricated refrigerant lines. Refer to the piping section of the Lennox Service Unit Information Manual (SUI-803-L9) for proper size, type and application of field-fabricated lines.

Separate discharge and suction service ports are provided at the service valves for connection of gauge manifold during charging procedure. Figures 10 shows HP32 refrigerant flow and gauge manifold connections.

TABLE 4

HP32 UNIT	LIQUID LINE	SUCTION LINE	L15 LINE SET
-24 -30 -36	3/8 in. (10 mm)	3/4 in. (19 mm)	L15-41 20 ft. - 50 ft. (6m - 15m)
-42 -48	3/8 in. (10 mm)	7/8 in. (22 mm)	L15-65 30 ft. - 50 ft. (9 m - 15m)
-60	3/8 in. (10 mm)	1-1/8 in. (29 mm)	Field Fabricated

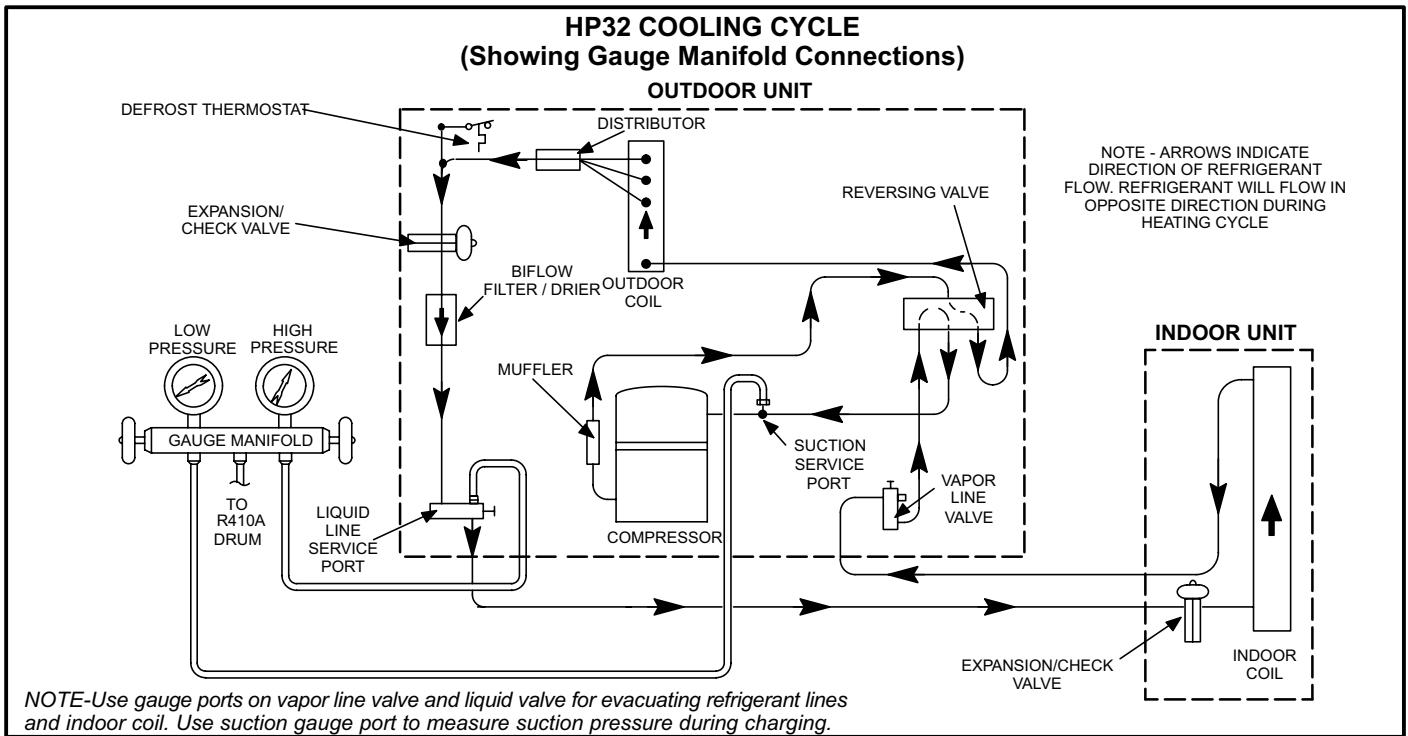

FIGURE 10

A-Service Valves

The liquid line and suction line service valves and gauge ports are accessible by removing the compressor access cover. Full service liquid and suction line valves are used. See figures 11 and 12. The service ports are used for leak testing, evacuating, charging and checking charge. Service valves have a factory-installed schrader valve. A service port cap is supplied to protect the schrader valve from contamination and assure a leak free seal. Valves are not rebuildable. If a valve has failed it must be replaced. The pressure tap fitting has a LIGHT MAROON tag to remind service technicians that the unit contains R410A.

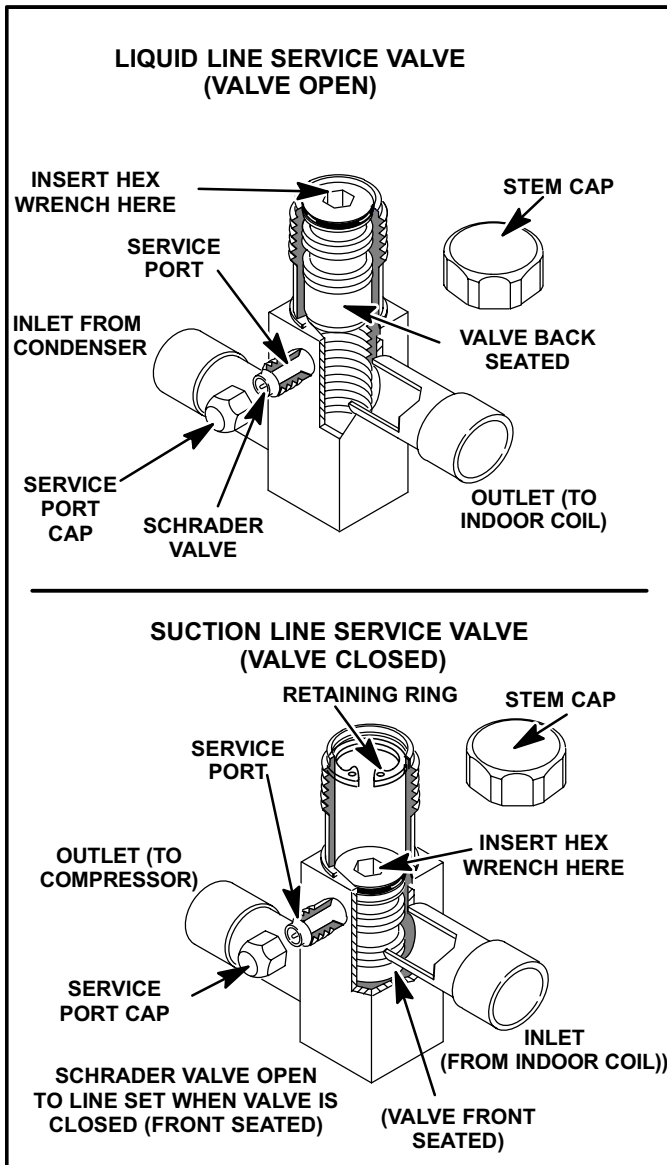

FIGURE 11

To Access Schrader Port:

- 1- Remove service port cap with an adjustable wrench.
- 2- Connect gauge to the service port.
- 3- When testing is completed, replace service port cap. Tighten finger tight, then an additional 1/6 turn.

To Open Liquid or Suction Line Service Valve:

- 1- Remove stem cap with an adjustable wrench.
- 2- Using service wrench and hex head extension (5/16" for suction line and 3/16" for liquid line) back the stem out counterclockwise until the valve stem just touches the retaining ring.
- 3- Replace stem cap and tighten finger tight, then tighten an additional 1/6 turn.

⚠ DANGER

Do not over backseat this valve (figure 11). Attempts to over backseat this valve will cause snap ring to explode from valve body under pressure of refrigerant. Personal injury and unit damage will result.

To Close Liquid or Suction Line Service Valve:

- 1- Remove stem cap with an adjustable wrench.
- 2- Using service wrench and hex head extension, (5/16" for suction line and 3/16" for liquid line) turn stem clockwise to seat the valve. Tighten firmly, but do not overtighten.
- 3- Replace stem cap. Tighten finger tight, then tighten an additional 1/6 turn.

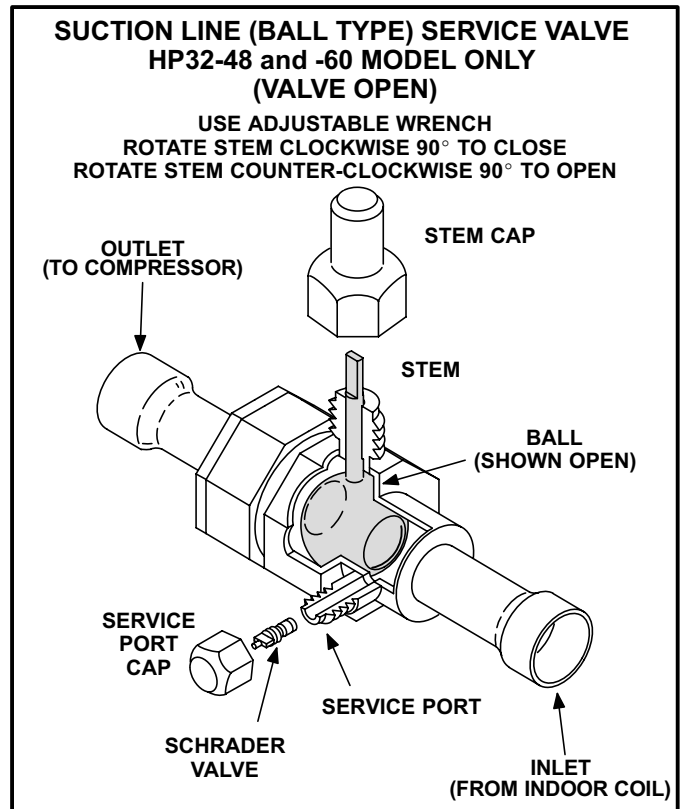

FIGURE 12

V-CHARGING

Units are factory charged with the amount of R410A refrigerant indicated on the unit rating plate. This charge is based on a matching indoor coil and outdoor coil with 20 ft. (6.1m) line set. For varying lengths of line set, refer to table 5 for refrigerant charge adjustment.

TABLE 5

Liquid Line Set Diameter	Ozs. per 5 ft. (grams per 1.5m) adjust from 20 ft. (6.1m) line set*
3/8 in. (10mm)	3 ounces per 5 feet (85g per 1.5m)

*If line length is greater than 20 ft. (6.1m), add this amount. If line length is less than 20 ft. (6.1m), subtract this amount.

A-Leak Testing

After the line set has been connected to the indoor and outdoor units, the line set connections and indoor unit must be checked for leaks.

⚠ WARNING

Never use oxygen or air to pressurize refrigeration or air conditioning systems. Oxygen or air will explode on contact with oil and could cause personal injury. When using high pressure gas such as nitrogen for this purpose, be sure to use a regulator that can control the pressure down to 1 or 2 psig (6.9 to 13.8 kPa).

Using an Electronic Leak Detector

- 1 - Connect the high pressure hose of the manifold gauge set to the service port of the vapor valve. (*Normally, the high pressure hose is connected to the liquid line port; however, connecting it to the vapor port better protects the manifold gauge set from high pressure damage.*)
- 2 - Connect a cylinder of R410A in the UPRIGHT position to the center port of the manifold gauge set.
- 3 - With both manifold valves closed, open the valve on the R410A bottle (vapor only).
- 4 - Open the high pressure side of the manifold to allow R410A into the line set and indoor unit. Weigh in a trace amount of R410A. [*A trace amount is a maximum of 2 ounces (57g) refrigerant or 3 pounds (31 kPa) pressure*]. Close the valve on the R410A bottle and the valve on the high pressure side of the manifold gauge set. Disconnect R410A bottle.
- 5 - Connect a cylinder of nitrogen with a pressure regulator valve to the center port of the manifold gauge set.
- 6 - Adjust nitrogen pressure to 150 psig (1034 kPa). Open the valve on the high side of the manifold gauge set which will pressurize line set and indoor unit.

- 7 - After a short period of time, open a refrigerant port to make sure the refrigerant added is adequate to be detected. (Amounts of refrigerant will vary with line lengths.) Check all joints for leaks. Purge nitrogen and R410A mixture. Correct any leaks and recheck.

⚠ IMPORTANT

Leak detector must be capable of sensing HFC refrigerant.

⚠ WARNING



**Danger of Explosion.
Can cause injury, death and equipment damage.
When using dry nitrogen, use a pressure-reducing regulator, set at 150 psig (1034 kPa) or less to prevent excessive pressure.**

B-Evacuating the System

Evacuating the system of non-condensables is critical for proper operation of the unit. Non-condensables are defined as any gas that will not condense under temperatures and pressures present during operation of an air conditioning system. Non-condensables and water vapor combine with refrigerant to produce substances that corrode copper piping and compressor parts.

- 1 - Connect manifold gauge set to the service valve ports as follows: low pressure gauge to suction line service valve; high pressure gauge to liquid line service valve.

IMPORTANT - Compliant scroll compressors (as with any refrigerant compressor) should never be used to evacuate a refrigeration or air conditioning system.

NOTE - A temperature vacuum gauge, mercury vacuum or thermocouple gauge should be used. The usual bourdon tube gauges are inaccurate in the vacuum range.

- 2 - Connect the vacuum pump (with vacuum gauge) to the center port of the manifold gauge set.
- 3 - Open both manifold valves and start vacuum pump.
- 4 - Evacuate the line set and indoor unit to an **absolute pressure** of 23mm of mercury or approximately 1 inch of mercury or 23,000 microns. During the early stages of evacuation, it is desirable to close the manifold gauge valve at least once to determine if there is a rapid rise in **absolute pressure**. A rapid rise in pressure indicates a relatively large leak. If this occurs, the leak testing procedure must be repeated.

*NOTE - The term **absolute pressure** means the total actual pressure within a given volume or system, above the absolute zero of pressure. Absolute pressure in a vacuum is equal to atmospheric pressure minus vacuum pressure.*

- 5 - When the absolute pressure reaches 23mm of mercury, close the manifold gauge valves, turn off the vacuum pump and disconnect the manifold gauge center port hose from vacuum pump. Attach the manifold center port hose to a nitrogen cylinder with pressure regulator set to 150 psig (1034 kPa) and purge the hose. Open the manifold gauge valves to break the vacuum in the line set and indoor unit. Close the manifold gauge valves.

⚠ WARNING

Danger of Equipment Damage. Avoid deep vacuum operation. Do not use compressors to evacuate a system. Extremely low vacuums can cause internal arcing and compressor failure. Damage caused by deep vacuum operation will void warranty.

- 6 - Shut off the nitrogen cylinder and remove the manifold gauge hose from the cylinder. Open the manifold gauge valves to release the nitrogen from the line set and indoor unit.
- 7 - Replace drier. Any time unit is exposed to air due to service, drier must be replaced. All replacement driers must be approved for R410A refrigerant.
- 8 - Reconnect the manifold gauge to the vacuum pump, turn the pump on and continue to evacuate the line set and indoor unit until the absolute pressure does not rise above .5mm mercury, or .197 inches of mercury or 500 microns within a 20 minute period after shutting off the vacuum pump and closing the manifold gauge valves.
- 9 - When the absolute pressure requirement above has been met, disconnect the manifold hose from the vacuum pump and connect it to an upright cylinder of R410A refrigerant. Open the manifold gauge valves to break the vacuum in the line set and indoor unit. Close manifold gauge valves and shut off R410A cylinder and remove manifold gauge set. Clean hands immediately once evacuation procedure is complete.

⚠ IMPORTANT

A temperature vacuum gauge, mercury vacuum (U-tube), or thermocouple gauge should be used. The usual Bourdon tube gauges are not accurate enough in the vacuum range.

⚠ IMPORTANT

The compressor should never be used to evacuate a refrigeration or air conditioning system.

C-Charging

This system is charged with R410A refrigerant which operates at much higher pressures than R22. The check/expansion valve provided with the unit is approved for use with R410A. Do not replace it with a valve designed for use with R22. This unit is NOT approved for use with coils which include metering orifices or capillary tubes.

Processing Procedure

The unit is factory-charged with the amount of R410A refrigerant indicated on the unit rating plate. This charge is based on a matching indoor coil and outdoor coil with a 20 foot (6.1m) line set. For varying lengths of line set, refer to table 5 for refrigerant charge adjustment. A blank space is provided on the unit rating plate to list actual field charge.

⚠ IMPORTANT

Mineral oils are not compatible with R410A. If oil must be added, it must be a poly ester oil.

For line set lengths longer than 50 ft add 1 ounce of oil for every additional 10 ft. of line set. Do not add any more than 7 oz. of oil. Copeland has approved Mobil EAL™ Arctic 22CC and ICI EMKARATE™ RL32CF for use with these compressors when oil must be added in the field.

It is desirable to charge the system in the cooling cycle if weather conditions permit. However, if the unit must be charged in the heating season, one of the following procedures must be followed to ensure proper system charge.

If the system is completely void of refrigerant, the recommended and most accurate method of charging is to weigh the refrigerant into the unit according to the total amount shown on the unit nameplate.

If weighing facilities are not available or if unit is just low on charge, use the following procedure:

- 1 - Connect gauge manifold as shown in figure 10. Connect an R410A drum to center port of gauge manifold.
- 2 - Record outdoor ambient temperature using a digital thermometer.
- 3 - Set room thermostat to 74°F (23°C) in "Emergency Heat" or "Heat" position and allow unit to run until heating demand is satisfied. This will create the necessary load for proper charging of system in cooling cycle. Change thermostat setting to 68°F (20°C) in "Cool" position. Allow unit to run until system pressures stabilize.
- 4 - Use the same digital thermometer used to check outdoor ambient temperature to check liquid line temperature.

5 - If outdoor temperature is 60°F (15°C) or above, use the approach method to check the refrigerant charge. The difference between ambient and liquid line temperatures should match values given in table 6. Refrigerant must be added to lower approach temperature. Remove refrigerant from system to increase approach temperature.

TABLE 6
Approach Values for Charging

Model Number	Approach Temperature Liquid Line Temp. - Outdoor Ambient °F (°C)
HP32-24	13 ± 1 (7.2 ± .5)
HP32-30	7 ± 1 (3.9 ± .5)
HP32-36	11 ± 1 (6.1 ± .5)
HP32-42	12.5 ± 1 (6.9 ± .5)
HP32-48	10 ± 1 (5.6 ± .5)
HP32-60	11.5 ± 1 (6.5 ± .5)

6 - If ambient temperature is less than 60°F (15°C), air flow might need to be restricted to achieve pressures in the 300-350 psig (2068-2413 kPa) range. See figure 13. These higher pressures are necessary for checking charge. Block equal sections of air intake panels, moving obstructions sideways as shown until liquid pressure is in the 300-350 psig (2068-2413 kPa) range.

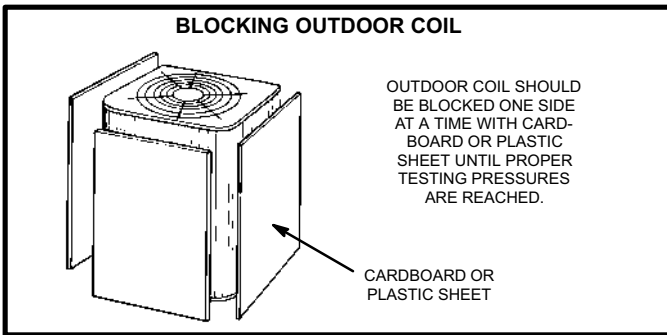

FIGURE 13

TABLE 7
Subcooling Values for Charging

Model Number	Subcooling Values Conversion Temp. - Liquid Line Temp. °F (°C)
HP32-24	5 ± 1 (2.8 ± .5)
HP32-30	8 ± 1 (7.4 ± .5)
HP32-36	5.5 ± 1 (3 ± .5)
HP32-42	4.5 ± 1 (2.5 ± .5)
HP32-48	2.5 ± 1 (1.4 ± .5)
HP32-60	6 ± 1 (3.3 ± .5)

7 - Read liquid line temperature. Read liquid line pressure from gauge and convert to heat pump temperature using the temperature/pressure chart for R410A refrigerant provided in table 9. The difference between the liquid line temperature and the conversion temperature is the subcooling temperature (subcooling = conversion temperature minus liquid temperature). Subcooling should approximate values given in table 7. Add refrigerant to increase subcooling and remove refrigerant to reduce subcooling. Be aware of the R410A refrigerant cylinder. It will be light maroon-colored. Refrigerant should be added through the vapor line valve in the liquid state. **Some R410A cylinders are equipped with a dip tube which allows you to draw liquid refrigerant from the bottom of the cylinder without turning the cylinder upside-down. The cylinder will be marked if it is equipped with a dip tube.**

8 - Use table 8 as a general guide when performing maintenance checks. This is not a procedure for charging unit. Minor variations in these pressures may be expected due to differences in installations. Significant differences could mean that the system is not properly charged or that a problem exists with some component in the system. Used carefully, this table could serve as a useful service guide.

TABLE 8
NORMAL OPERATING PRESSURES
(Liquid ±10 and Vapor ±5 psig)

COOLING OPERATION												
OUTDOOR COIL ENTERING AIR TEMP. °F (°C)	HP32-24		HP32-30		HP32-36		HP32-42		HP32-48		HP32-60	
	Liquid	Vapor	Liquid	Vapor	Liquid	Vapor	Liquid	Vapor	Liquid	Vapor	Liquid	Vapor
65 (18.3)	252	131	233	141	216	136	240	133	228	137	231	124
75 (23.9)	291	133	272	142	276	138	281	135	265	139	269	126
85 (29.4)	337	135	314	143	298	139	325	137	304	141	315	127
95 (35.0)	371	140	360	146	359	141	372	138	348	142	370	133
105 (40.6)	421	142	413	148	400	143	428	142	405	145	415	136
HEATING OPERATION												
OUTDOOR COIL ENTERING AIR TEMP. °F (°C)	HP32-24		HP32-30		HP32-36		HP32-42		HP32-48		HP32-60	
	Liquid	Vapor	Liquid	Vapor	Liquid	Vapor	Liquid	Vapor	Liquid	Vapor	Liquid	Vapor
20 (-6.6)	288	60	270	67	234	62	340	65	313	60	245	55
30 (-1.1)	306	75	297	84	257	80	350	72	330	73	287	66
40 (4.4)	325	90	325	100	318	93	353	83	346	87	332	82
50 (10.0)	344	105	353	117	322	103	358	101	366	101	347	99

TABLE 9
R410A Temperature/Pressure Chart

Temperature °F	Pressure Psig	Temperature °F	Pressure Psig	Temperature °F	Pressure Psig	Temperature °F	Pressure Psig
32	100.8	63	178.5	94	290.8	125	445.9
33	102.9	64	181.6	95	295.1	126	451.8
34	105.0	65	184.3	96	299.4	127	457.6
35	107.1	66	187.7	97	303.8	128	463.5
36	109.2	67	190.9	98	308.2	129	469.5
37	111.4	68	194.1	99	312.7	130	475.6
38	113.6	69	197.3	100	317.2	131	481.6
39	115.8	70	200.6	101	321.8	132	487.8
40	118.0	71	203.9	102	326.4	133	494.0
41	120.3	72	207.2	103	331.0	134	500.2
42	122.6	73	210.6	104	335.7	135	506.5
43	125.0	74	214.0	105	340.5	136	512.9
44	127.3	75	217.4	106	345.3	137	519.3
45	129.7	76	220.9	107	350.1	138	525.8
46	132.2	77	224.4	108	355.0	139	532.4
47	134.6	78	228.0	109	360.0	140	539.0
48	137.1	79	231.6	110	365.0	141	545.6
49	139.6	80	235.3	111	370.0	142	552.3
50	142.2	81	239.0	112	375.1	143	559.1
51	144.8	82	242.7	113	380.2	144	565.9
52	147.4	83	246.5	114	385.4	145	572.8
53	150.1	84	250.3	115	390.7	146	579.8
54	152.8	85	254.1	116	396.0	147	586.8
55	155.5	86	258.0	117	401.3	148	593.8
56	158.2	87	262.0	118	406.7	149	601.0
57	161.0	88	266.0	119	412.2	150	608.1
58	163.9	89	270.0	120	417.7	151	615.4
59	166.7	90	274.1	121	423.2	152	622.7
60	169.6	91	278.2	122	428.8	153	630.1
61	172.6	92	282.3	123	434.5	154	637.5
62	195.5	93	286.5	124	440.2	155	645.0

VI-SERVICE AND RECOVERY

⚠ WARNING

Polyol ester (POE) oils used with R410A refrigerant absorb moisture very quickly. It is very important that the refrigerant system be kept closed as much as possible. **DO NOT** remove line set caps or service valve stub caps until you are ready to make connections.

⚠ IMPORTANT

Use recovery machine rated for R410 refrigerant.

If the HP32 system must be opened for any kind of service, such as compressor or drier replacement, you must take extra precautions to prevent moisture from entering the system. The following steps will help to minimize the amount of moisture that enters the system during recovery of R410A.

- 1 - Use a regulator-equipped nitrogen cylinder to break the system vacuum. Do not exceed 5 psi. The dry nitrogen will fill the system, and will help purge any moisture.
- 2 - Remove the faulty component and quickly seal the system (using tape or some other means) to prevent additional moisture from entering the system.
- 3 - Do not remove the tape until you are ready to install new component. Quickly install the replacement component.
- 4 - Evacuate the system to remove any moisture and other non-condensables.

Any time the HP32 sealed system is opened, the drier must be replaced and the system must be evacuated.

Any moisture not absorbed by the polyol ester oil can be removed by triple evacuation. Moisture that has been absorbed by the compressor oil can be removed by replacing the drier.

⚠ IMPORTANT

Evacuation of system only will not remove moisture from oil. Drier must be replaced to eliminate moisture from POE oil.

VII-MAINTENANCE

In order to maintain the warranty on this equipment, the HP32 system must be serviced annually and a record of service maintained. The following should be checked between annual maintenance:

A-Outdoor Unit

- 1- Clean and inspect condenser coil. (Coil may be flushed with a water hose).
- 2- Visually inspect all connecting lines, joints and coils for evidence of oil leaks.

⚠ IMPORTANT

If insufficient heating or cooling occurs, the unit should be gauged and the refrigerant charge should be checked.

B-Indoor Coil

- 1- Clean coil if necessary.
- 2- Check connecting lines and coil for oil leaks.
- 3- Check condensate line and clean if necessary.

C-Indoor Unit

- 1- Clean or change filters.
- 2- Adjust blower cooling speed. Check static pressure drop over coil to determine correct blower CFM. Refer to Lennox Engineering Handbook.
- 3- Belt Drive Blowers - Check condition/tension.
- 4- Check all wiring for loose connections.
- 5- Check for correct voltage at unit.
- 6- Check amp-draw on blower motor.
Unit nameplate _____ Actual _____.

VIII-DIAGRAM / OPERATING SEQUENCE

HP32-024/060-1/2 UNITS

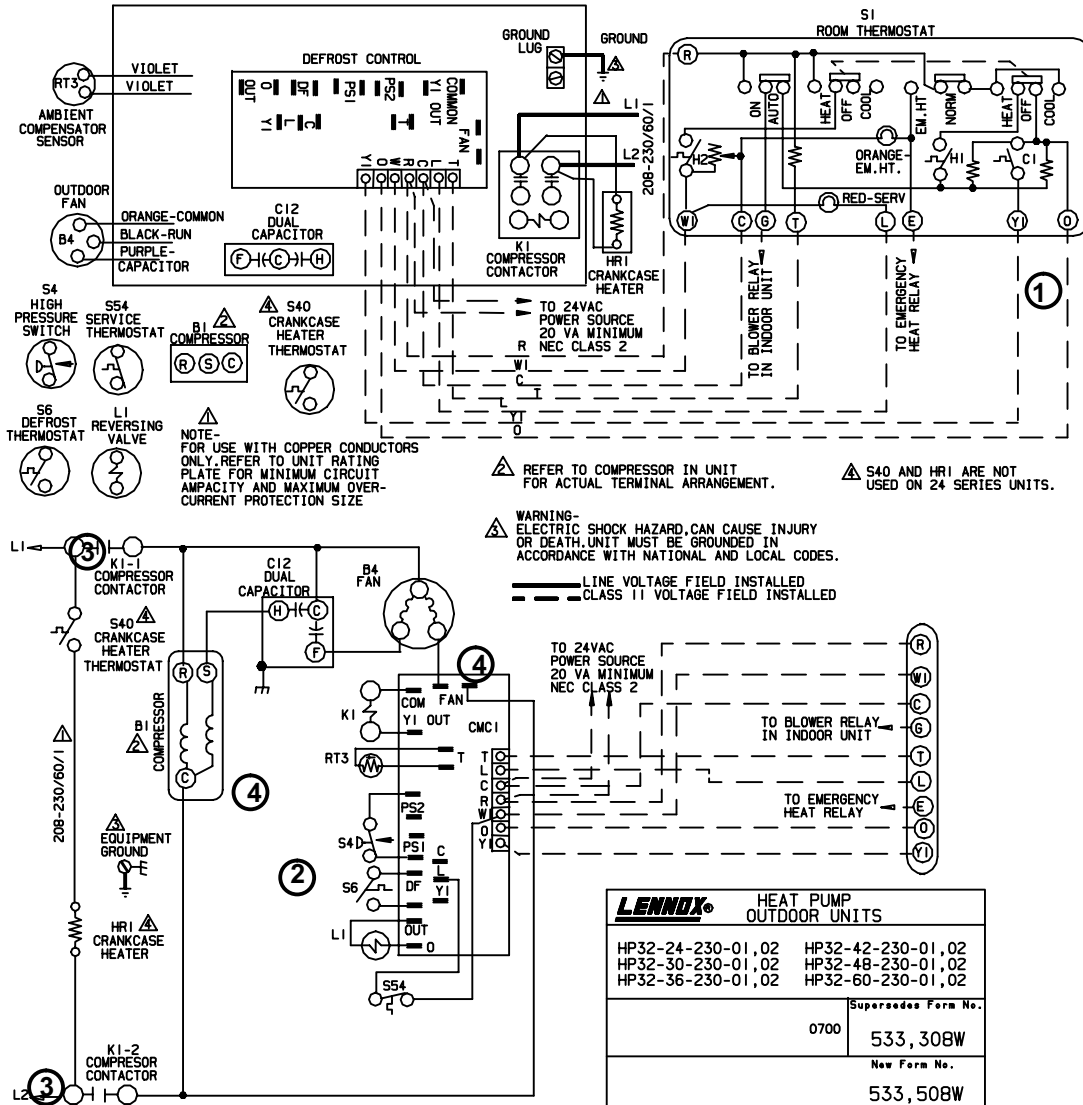

COOLING

Transformer from indoor unit supplies 24VAC power to the thermostat and outdoor unit controls.

- 1- Internal wiring energizes terminal O by cooling mode selection, energizing the reversing valve. Cooling demand initiates at Y1 in the thermostat.
- 2- 24VAC energizes N.C. high pressure limit S4 energizing compressor contactor K1.
- 3- K1-1 and K1-2 N.O. closes energizing compressor B1 and outdoor fan motor B4.
- 4- Compressor B1 and outdoor fan motor B4 begin immediate operation.

HEATING

- 1- Internal wiring de-energizes terminal O by heating mode selection, de-energizing the reversing valve. Heating demand initiates at Y1.
- 2- 24VAC energizes N.C. high pressure limit S4, energizing compressor contactor K1.
- 3- K1-1 and K1-2 N.O. closes energizing compressor and outdoor fan motor
- 4- Compressor B1 and outdoor fan motor B4 begin immediate operation.

DEFROST MODE

- 1 - During heating operation when outdoor coil temperature drops below 35°F defrost switch (thermostat) S6 closes.
- 2 - Defrost control CMC1 begins timing. If defrost thermostat (S6) remains closed at the end of the 30,60 or 90 minute period, defrost relay energizes and defrost begins.
- 3 - During defrost CMC1 energizes the reversing valve and W1 on the terminal strip (operating indoor unit on the first stage heat mode), while de-energizing outdoor fan motor B4.
- 4 - Defrost continues 14 ± 1 minutes or until thermostat switch (S6) opens. When defrost thermostat opens, defrost control timer loses power and resets.
- 5 - When CMC1 resets, the reversing valve and W1 on the terminal strip are de-energized, while the outdoor fan motor B4 is energized.
- 6 - After each thermostat demand, time delaylocks out the circuit to compressor contactor coil and defrost control for 5 minutes \pm 2 minutes. At the end of the timed period, the time delay allows the compressor contactor and defrost control to be energized upon demand as in step 1.

LENNOX® HEAT PUMP OUTDOOR UNITS	
HP32-24-230-01,02	HP32-42-230-01,02
HP32-30-230-01,02	HP32-48-230-01,02
HP32-36-230-01,02	HP32-60-230-01,02
Supersedes Form No.	
0700	
533, 308W	
New Form No.	
533, 508W	

©2000 Lennox Industries Inc.

Litho U.S.A.

HP32-024/060-3 UNITS

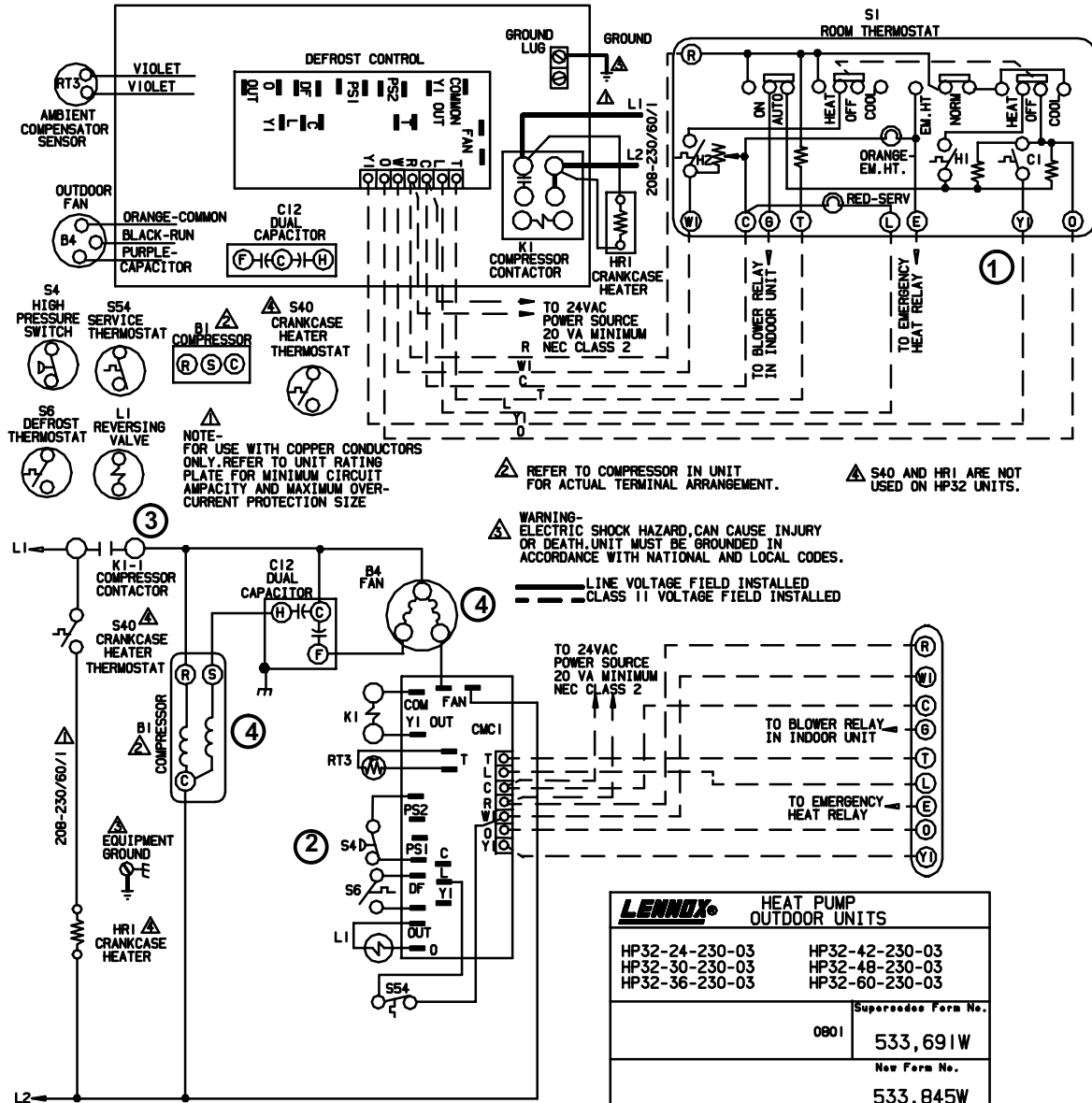

COOLING

Transformer from indoor unit supplies 24VAC power to the thermostat and outdoor unit controls.

- 1- Internal wiring energizes terminal O by cooling mode selection, energizing the reversing valve. Cooling demand initiates at Y1 in the thermostat.
- 2- 24VAC energizes N.C. high pressure limit S4 energizing compressor contactor K1.
- 3- K1-1 N.O. closes energizing compressor B1 and outdoor fan motor B4.
- 4- Compressor B1 and outdoor fan motor B4 begin immediate operation.

HEATING

- 1- Internal wiring de-energizes terminal O by heating mode selection, de-energizing the reversing valve. Heating demand initiates at Y1.
- 2- 24VAC energizes N.C. high pressure limit S4, energizing compressor contactor K1.
- 3- K1-1 N.O. closes energizing compressor and outdoor fan motor
- 4- Compressor B1 and outdoor fan motor B4 begin immediate operation.

DEFROST MODE

- 5- During heating operation, when outdoor coil drops below $35 \pm 4^\circ$ F, the defrost thermostat S6 closes. When defrost thermostat closes, defrost timer begins timing. If defrost thermostat remains closed at the end of 30, 60 or 90 minutes, defrost control energizes and defrost begins.
- 6- When defrost control energizes, reversing valve L1 and indoor electric heat relay are energized. Outdoor fan is de-energized.
- 7- Defrost continues until 14 ± 1 minutes have elapsed or until the defrost thermostat S6 opens. When defrost thermostat opens to terminate defrost, the defrost timer loses power and resets. Defrost timing is stopped until the next call for defrost (when defrost thermostat closes).
- 8- After each thermostat demand, time delay locks-out the circuit to compressor contactor coil and defrost control for 5 ± 2 minutes. At the end of the timed period, the time delay allows the compressor contactor and defrost control to be energized upon demand as in step 1.

LENNOX® HEAT PUMP OUTDOOR UNITS	
HP32-24-230-03	HP32-42-230-03
HP32-30-230-03	HP32-48-230-03
HP32-36-230-03	HP32-60-230-03
0801	Supersedes Form No. 533,691W
	New Form No. 533,845W

©2001 Lennox Industries Inc.

LiHo U.S.A.

HP32-024/060-4 UNITS

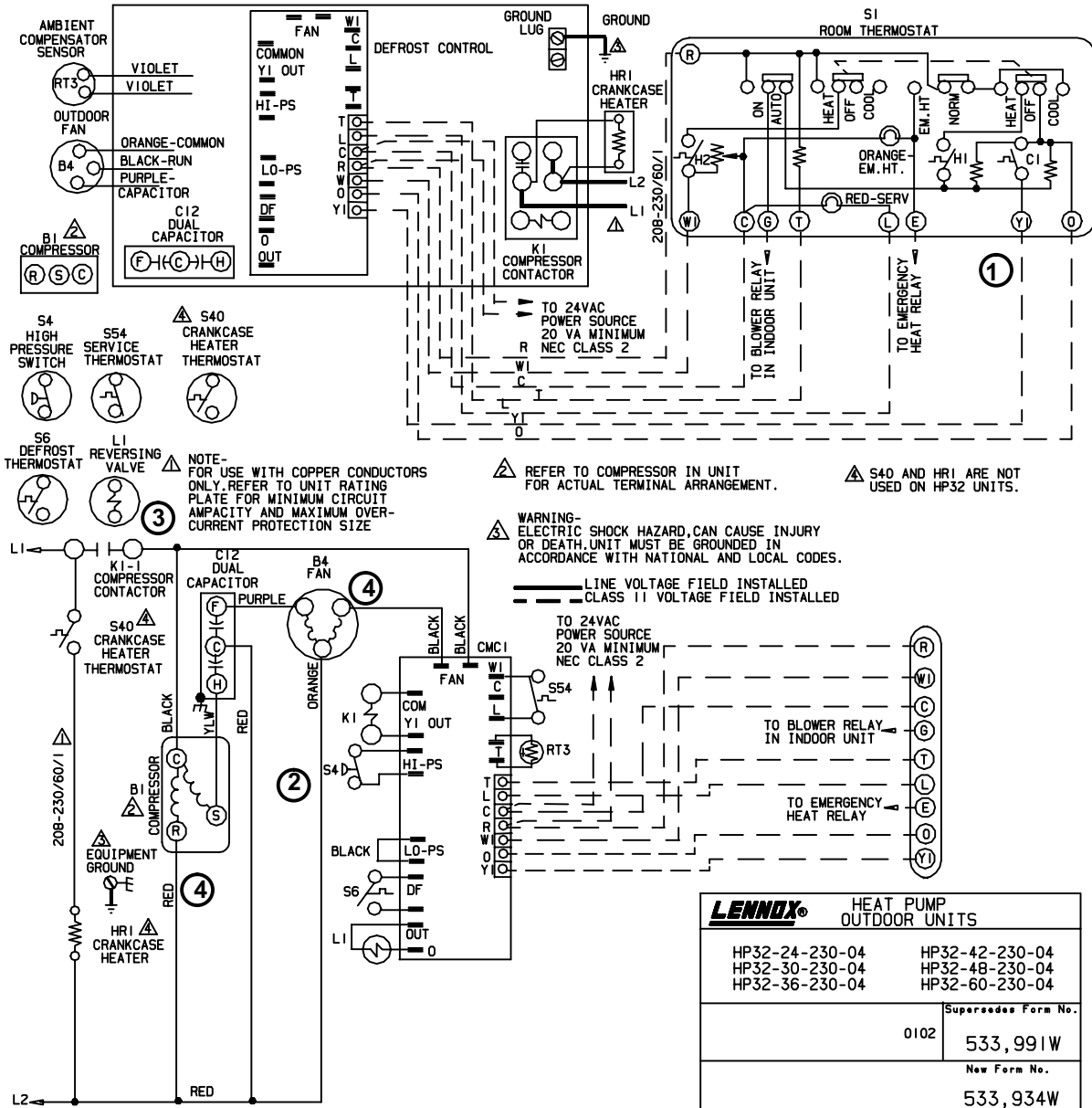

COOLING

Transformer from indoor unit supplies 24VAC power to the thermostat and outdoor unit controls.

- 1- Internal wiring energizes terminal O by cooling mode selection, energizing the reversing valve. Cooling demand initiates at Y1 in the thermostat.
- 2- 24VAC energizes N.C. high pressure limit S4 energizing compressor contactor K1.
- 3- K1-1 N.O. closes energizing compressor B1 and outdoor fan motor B4.
- 4- Compressor B1 and outdoor fan motor B4 begin immediate operation.

HEATING

- 1- Internal wiring de-energizes terminal O by heating mode selection, de-energizing the reversing valve. Heating demand initiates at Y1.
- 2- 24VAC energizes N.C. high pressure limit S4, energizing compressor contactor K1.
- 3- K1-1 N.O. closes energizing compressor and outdoor fan motor
- 4- Compressor B1 and outdoor fan motor B4 begin immediate operation.

DEFROST MODE

- 1- During heating operation when outdoor coil temperature drops below 42°F (5.5°C) defrost switch (thermostat) S6 closes.
- 2- Defrost control CMC1 begins timing. If defrost thermostat (S6) remains closed at the end of the 30, 60 or 90 minute period, defrost relay energizes and defrost begins.
- 3- During defrost CMC1 energizes the reversing valve and W1 on the terminal strip (operating indoor unit on the first stage heat mode), while de-energizing outdoor fan motor B4.
- 4- Defrost continues 14 ± 1 minutes or until thermostat switch (S6) opens. When defrost thermostat opens, defrost control timer loses power and resets.
- 5- When CMC1 resets, the reversing valve and W1 on the terminal strip are de-energized, while the outdoor fan motor B4 is energized.
- 6- After each thermostat demand, time delaylocks out the circuit to compressor contactor coil and defrost control for 5 minutes ± 2 minutes. At the end of the timed period, the time delay allows the compressor contactor and defrost control to be energized upon demand as in step 1.